

PARTS LIST

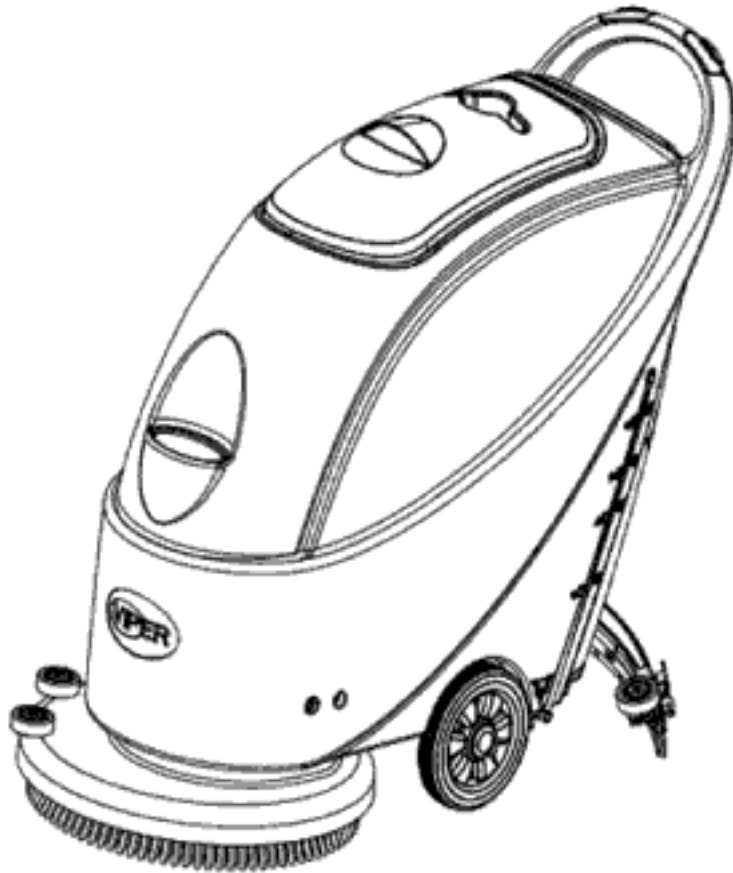

2021.01.28

TABLE OF CONTENTS

BATTERY VERSION - GENERAL VIEW	1
BATTERY VERSION - CONTROL SYSTEM AND ELECTRICAL SYSTEM	3
BATTERY VERSION - TANK SYSTEM	5
BATTERY VERSION - WHEELS AND SOLUTION SYSTEM	7
BATTERY VERSION - WEAR AND TEAR PARTS	9
BATTERY VERSION - WIRING DIAGRAM	11
CABLE VERSION - GENERAL VIEW	13
BATTERY VERSION - BRUSH SYSTEM	15
CABLE VERSION - BRUSH SYSTEM	17
CABLE VERSION - CONTROL SYSTEM AND ELECTRICAL SYSTEM	19
CABLE VERSION - TANK SYSTEM	21
CABLE VERSION - WEAR AND TEAR PARTS	23
CABLE VERSION - WHEELS AND SOLUTION SYSTEM	25
CABLE VERSION - WIRING DIAGRAM	27
BATTERY AND CABLE VERSION - SQUEEGEE SYSTEM	29

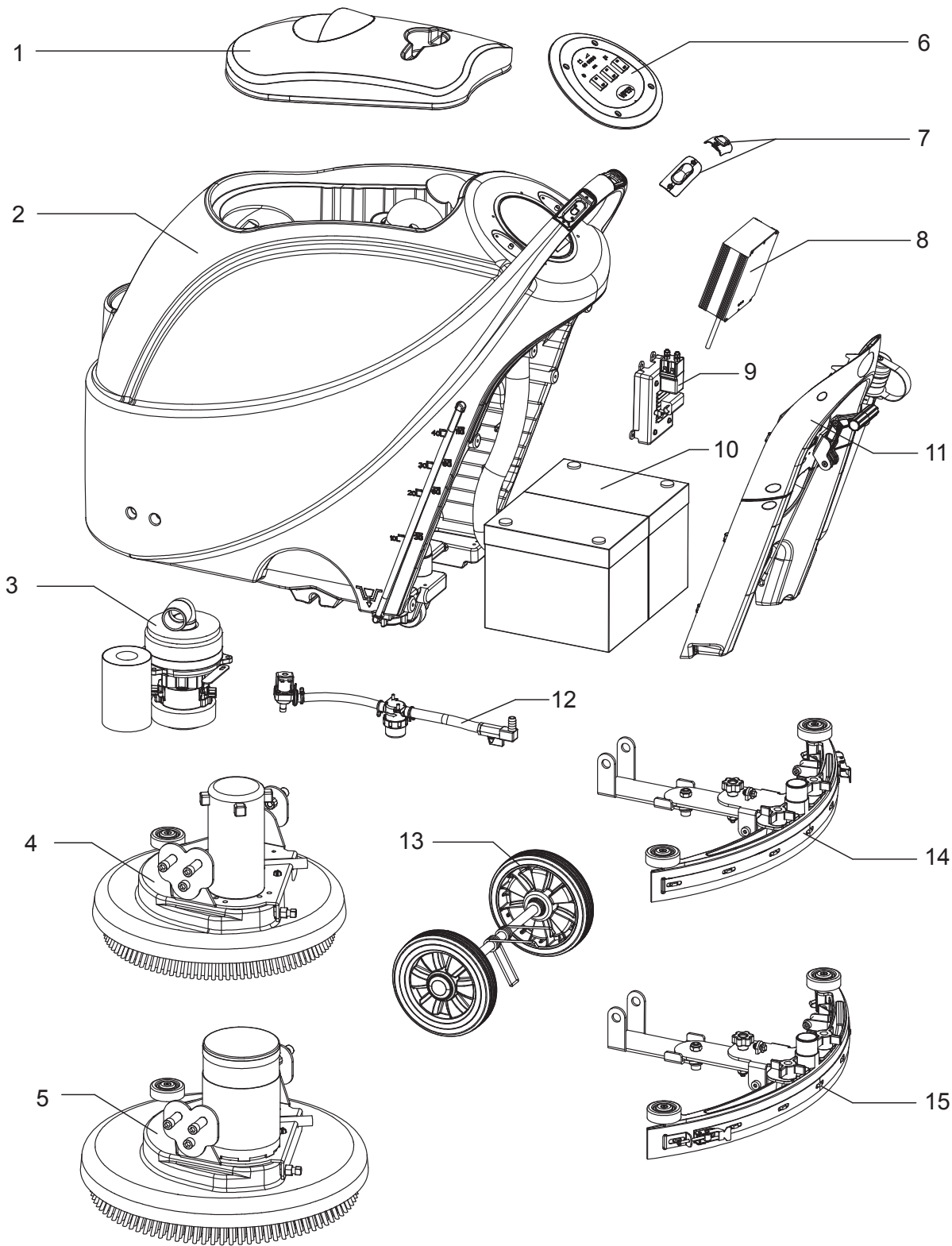

Pos.	Artikel-Nr.	Menge	Variante	Notes
1		1	COVER TANK ASSEMBLY	[1]
2		1	TANK ASSEMBLY	[1]
3		1	SUCTION PUMP SYSTEM	[1]
4A		1	17"BRUSH SYSTEM	[2]
5B		1	20"BRUSH SYSTEM	[2]
6		1	SWITCH PANEL ASSEMBLY	[3]
7		1	SAFETY SWITCH ASSEMBLY	
8		1	CHARGER	[3]
9		1	CONTROL PANEL BOARD	[3]
10		1	BATTERY ASSEMBLY	[1]
11		1	CONTROL PANEL SYSTEM	[3]
12		1	SOLUTION SYSTEM	[4]
13		1	WHEEL ASSEMBLY	[4]
14A		1	17"SQUEEGEE SYSTEM	[5]
15B		1	20"SQUEEGEE SYSTEM	[5]

Part Notes:

- [1] - See BATTERY VERSION - TANK SYSTEM
- [2] - See BATTERY VERSION - BRUSH SYSTEM
- [3] - See BATTERY VERSION - CONTROL SYSTEM AND ELECTRICAL SYSTEM
- [4] - See BATTERY VERSION - WHEELS AND SOLUTION SYSTEM
- [5] - See BATTERY AND CABLE VERSION - SQUEEGEE SYSTEM

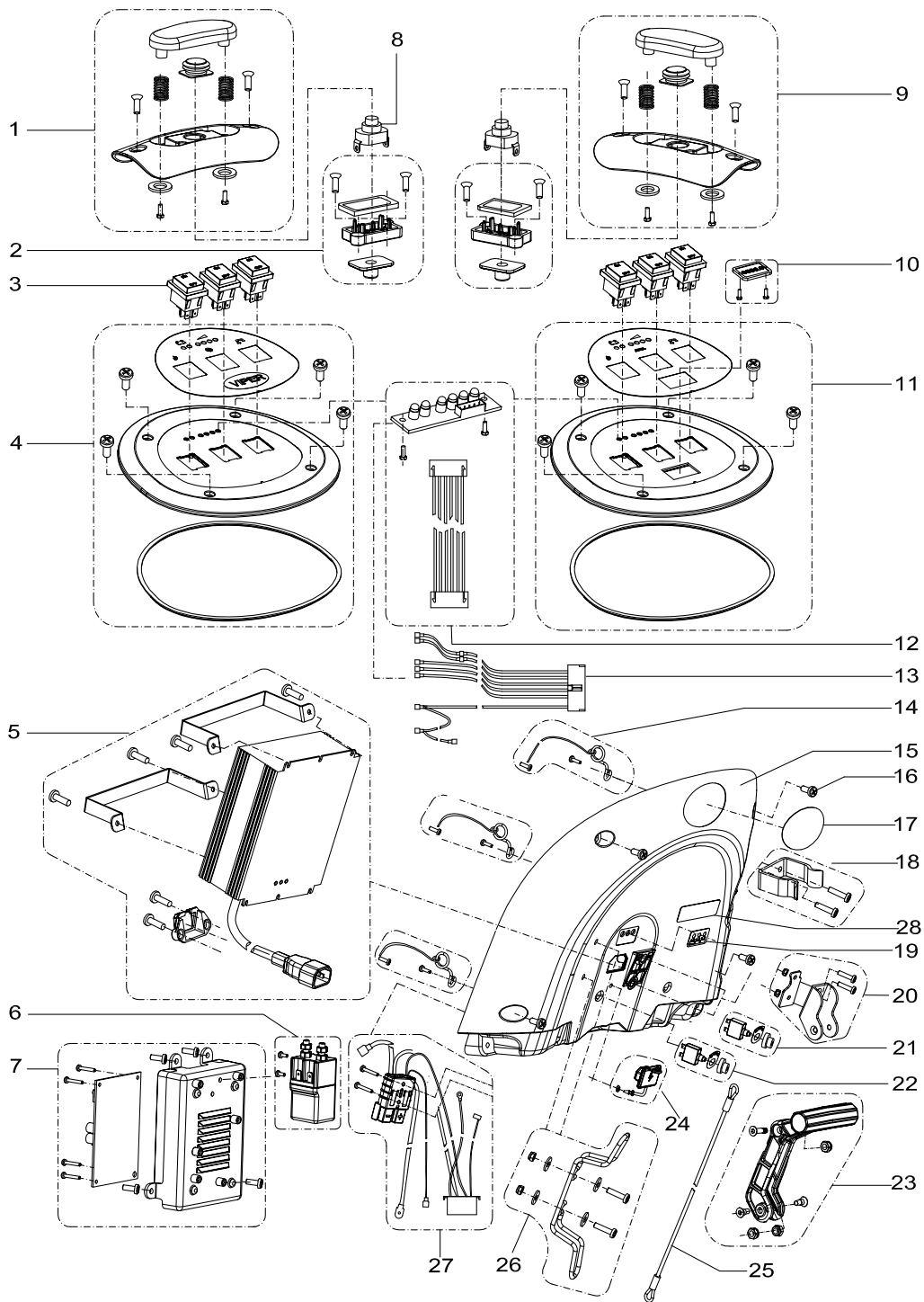

BATTERY VERSION - CONTROL SYSTEM AND ELECTRICAL SYSTEM

AS510

2017.11.16

Pos.	Artikel-Nr.	Menge	Variante	Notes
1	VF90266	1	LEFT BUTTON SAFETY SWITCH KIT	
2	VF90268	2	MOUNTING FRAME SWITCH KIT	
3	VV60153	3	Schalter RL2 P	
4A	VF90269	1	17 SWITCH COVER KIT	
5	VF90271-EU	1	CHARGER KIT EU VERSION	
5	VF90271-UK	1	CHARGER KIT UK VERSION	
6	VF90292	1	ELECTROMAGNETIC SWITCH KIT	
7	VF90272	1	17 CONTROL PANEL BOARD KIT	
8	VF90252	2	SWITCH	
9	VF90267	1	SAFETY SWITCH KNOB LEFT KIT	
10B	VF90291	1	HOUR METER KIT	
11B	VF90270	1	20 SWITCH COVER KIT	
12A	VF90290	1	LED BOARD CONNENTER CABLE KIT	
13A	VF90250	1	SWITCH CONNENTER CABLE KIT	
13B	VF90250-1	1	CABLE KIT FOR SWITCH CONNENTER 20INCH	
14	VF90274	3	NYLON CABLE HOOK KIT	
15	VF90205	1	COVER CONTROL HOUSING	
16	GT13054	4	Flachkopfschraube M5x12	
17A	VF90003-EU	1	17INCH SERIAL NUMBER LABEL	
17A	VF90003-UK	1	17INCH SERIAL LABEL	
17B	VF90007-EU	1	20INCH SERIAL NUMBER LABEL	
17B	VF90007-UK	1	20INCH SERIAL LABEL	
18	VF90275	1	CLAMP DRAIN HOSE KIT	
19	VF90004	1	LABEL BATTERY LEVEL	
20	VF90276	1	HAND BRACKET KIT	
21	VF90808	1	CIRCUIT BREAKER KIT FOR VACUUM MOTOR	
22	VF90278	1	CIRCUIT BREAKER KIT	
23	VF90277	1	HANDLE LIFT KIT	
24	VF90279	1	POWER SAFETY COVER KIT	
25	VF90114	1	CABLE SQUEEGEE LIFT	
26	VF90280	1	CORD WRAP KIT	
27A	VF90281	1	MAIN CABLE KIT	
27B	VF90281-1	1	MAIN CABLE KIT	[1]
28	VF90023	1		

Part Notes:

[1] - GUARANTEE DATE EXPIRED

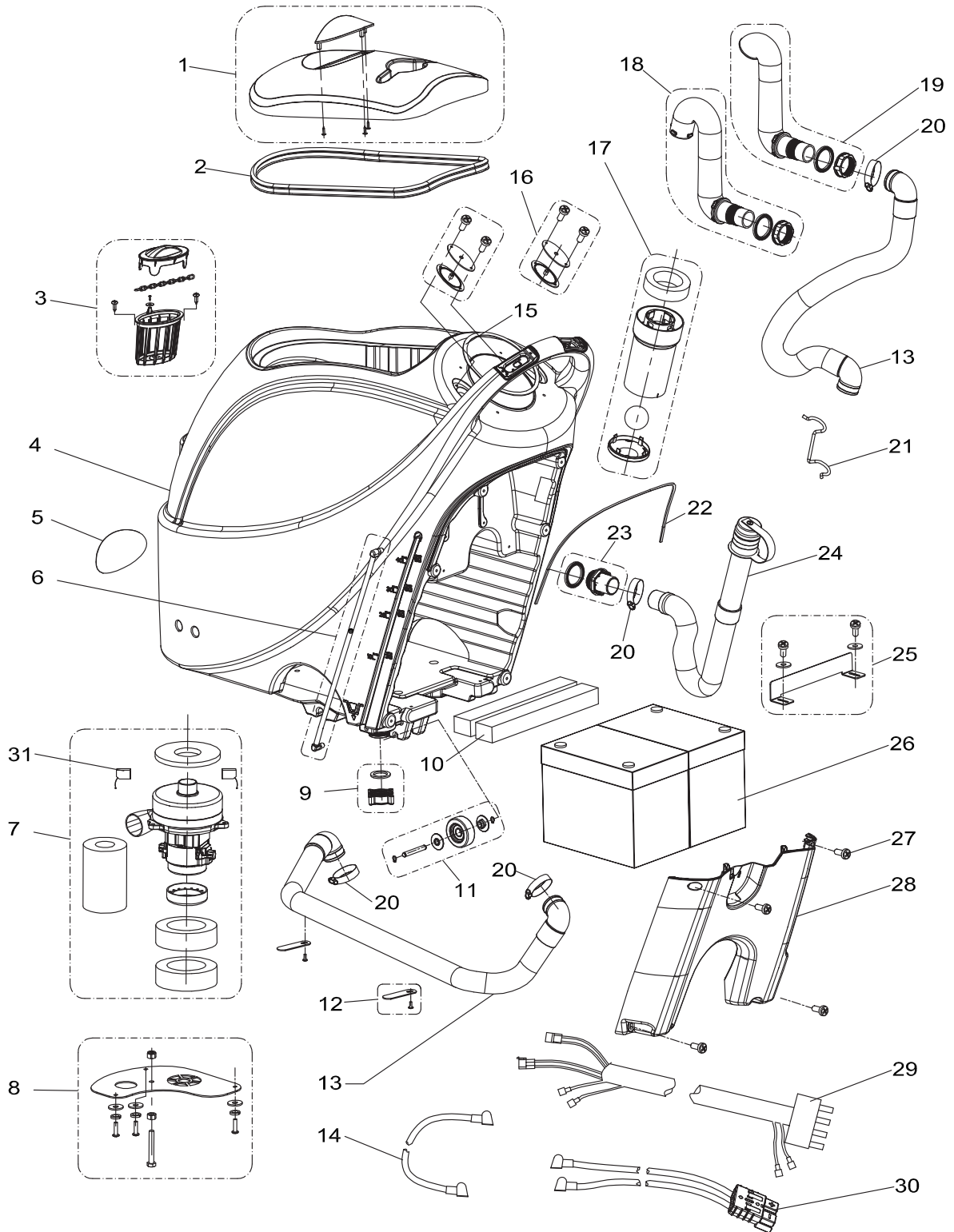

Pos.	Artikel-Nr.	Menge	Variante	Notes
1	VF90535	1	RECOVERY TANK KIT	
2	VF90504	1	Dichtung für Schmutzwassertank	
3	VF90619	1	Tankfilter	
4	VF90501	1	TANK BATTERY VERSION	
5	VF90011	1	LOGO LABEL	
6	VF90622	1	WATER LEVEL INDICATION KIT	
7	VF90293	1	Motor	
8	VF90264	1	Motorabdeckung	
9	VF90536	1	ABDECKUNGSSET WASSERABLAUF	
10	VF90533	2	BATTERY SPACER PANEL	
11	VF90312	1	2.5 WHEEL KIT	
12	VF90537	1	Halterung für Saugschlauch	
13	VF90508	2	Saugschlauch	
14	VF90246	1	Batteriekabel	
15	VF90231	1	GASKET	
16	VF90265	2	SEAL PLATE KIT	
17	VF90534	1	FLOAT KIT	
18	VF90538	1	SUCTION TUBE CONNECTER KIT	
19	VF90539	1	Schmutzwasserschlauch Kit	
20	VV10113	4	Klammer	
21	VF83150	1	Schlauchhalterung	
22	VF90218	1	CONTROL SEAL GASKET	
23	VF90446	1	DRAIN HOSE CONNECTER KIT	
24	VF90443	1	Ablassschlauch	
25	VF90540	1	BATTERY BRACKET KIT	
26A	1464853000	2	Gelbatterie 12V-87 Ah	
27	GT13054	4	Flachkopfschraube M5x12	
28	VF90206	1	BATTERY COVER	
29	VF90254	1	WIRE HARNESS MOTOR	
30	VF90247	1	POWER CABLE	
31	VF90522	2	KOHLEBÜRSTE FÜR VAKUUMMOTOR	

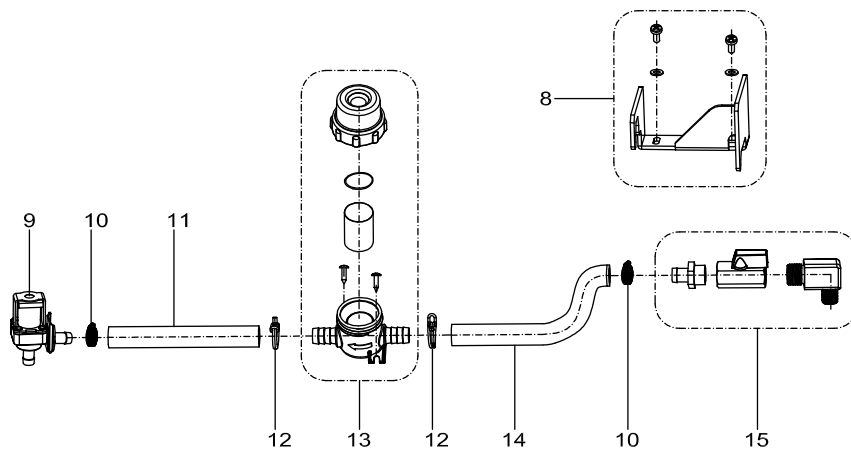
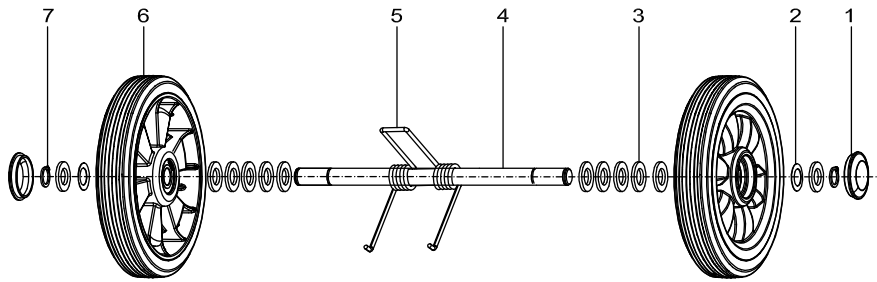

Pos.	Artikel-Nr.	Menge	Variante	Notes
1	VF89203	2	HUB CAP	
2	VF14563	2	WAVE WASHER	
3	VF14554	12	WASHER	
4	VF90304	1	WHEEL SHAFT	
5	VF82172	1	LOCK SPRING	
6	VF90305	2	8 WHEEL	
7	VF14552	2	RING D 17	
8	VF90623	1	SOLENOID VALVE BRACKET KIT	
9	VF90282	1	Magnetventil für AS430/510B+C	[1]
10	VV10114	2	Klammer	
11	VF90440	1	TUBING 260MM	
12	VF82148	2	Klammer 16 mm	
13	VF90621	1	FILTER KIT	
14	VF90441	1	TUBING 160MM	
15	VF90624	1	Kugelventilkit	

Part Notes:

[1] - Battery version

BATTERY VERSION - WEAR AND TEAR PARTS

AS510

2017.11.02

2018.04.16

Pos.	Artikel-Nr.	Menge	Variante	Notes
1	VF90504	1	Dichtung für Schmutzwassertank	
2	VF90619	1	Tankfilter	
3	VF90293	1	Motor	
4	VF90536	1	ABDECKUNGSSET WASSERABLAUF	
5	VF90312	1	2.5 WHEEL KIT	
6	VF90508	2	Saugschlauch	
7	VF90534	1	FLOAT KIT	
8	VF90443	1	Ablassschlauch	
9	VF90254	1	WIRE HARNESS MOTOR	
10	VF90247	1	POWER CABLE	
11	VV60153	3	Schalter RL2 P	
12	VF90271-EU	1	CHARGER KIT EU VERSION	
12	VF90271-UK	1	CHARGER KIT UK VERSION	
13	VF90272	1	17 CONTROL PANEL BOARD KIT	
14	VF90252	2	SWITCH	
15	VF90290	1	LED BOARD CONNENTER CABLE KIT	
16	VF90808	1	CIRCUIT BREAKER KIT FOR VACUUM MOTOR	
17	VF90278	1	CIRCUIT BREAKER KIT	
18	VF90114	1	CABLE SQUEEGEE LIFT	
19	VF90281	1	MAIN CABLE KIT	
20	VF90289	1	FUSE KIT	
21	VF90305	2	8 WHEEL	
22	VF90282	1	Magnetventil für AS430/510B+C	
23	VF90621	1	FILTER KIT	
24	VF90624	1	Kugelventilkit	
25	VF90299	1	BRUSH MOTOR AS430-AS510 EU VERSION	
26	VF90137	1	ROLLER KIT BUMPER	
27	VF90450	1	BRUSH SPRING CLIP KIT	
28	VF90444	1	DRIVEN PULLEY KIT	
29	VF90408	1	PULLEY BELT	
30A	VF90411	1	17BRUSH	
30B	VF90417	1	20BRUSH	
31	VF90141	1	Justierknopf	
32	VF81210	2	Flügelmutter	
33	VF90137	2	ROLLER KIT BUMPER	
34	VF90136	2	SQUEEGEE ROLL WHEEL KIT	
35A	VF90103	1	17 BLADE FRONT	
35A	VF90146	1	Sauglippen	
35B	VF90119	1	20 BLADE FRONT	
35B	VF90148	1	Sauglippen	
36A	VF90104	1	17 BLADE REAR	
36A	VF90147	1	Sauglippen	
36B	VF90120	1	20 BLADE REAR	
36B	VF90149	1	Sauglippen	
37A	VF90453	1	17INCH PAD HOLDER	
37B	VF90454	1	20INCH PAD HOLDER	

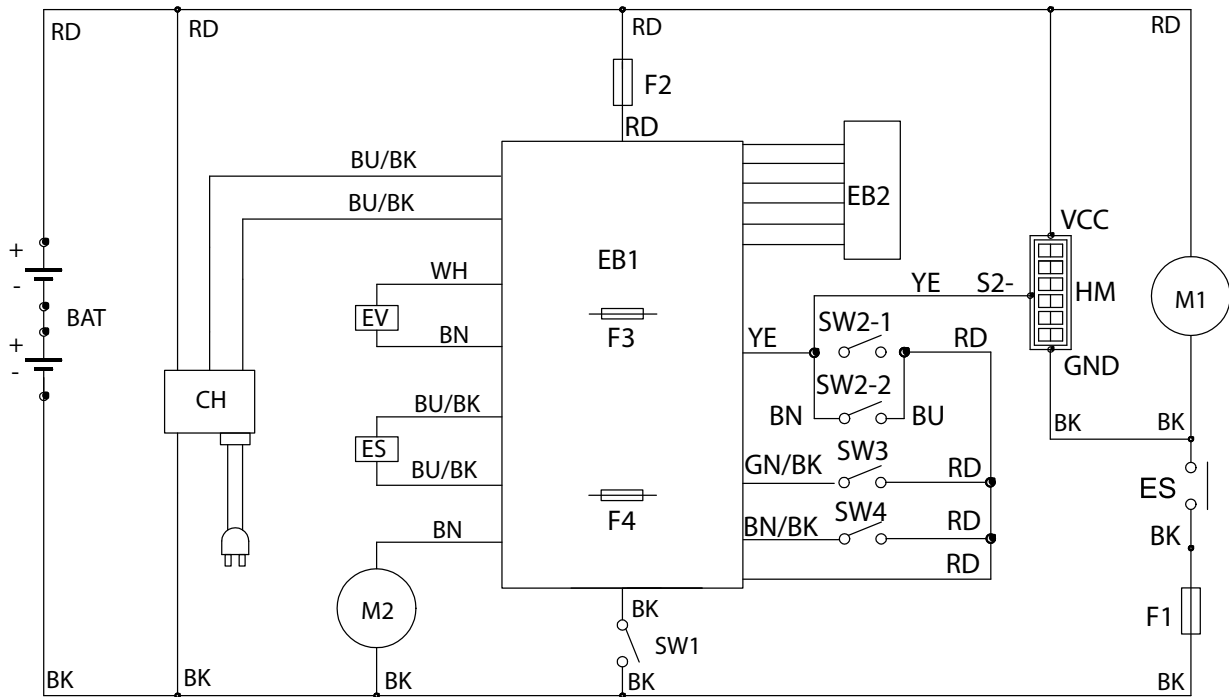

Pos.	Artikel-Nr.	Menge	Variante	Notes
BAT		1	Battery	
CH	VF90227-EU	1		
CH	VF90227-UK	1		
EB1	VF90238-1	1	PCB 17INCH CONTROL PANEL	[1]
EB2	VF90238-2	1	LED INDICATOR BATTERY LEVEL	
ES	VF90230	1	RELAY 24V DC	
EV	VF90282	1	Magnetventil für AS430/510B+C	
F1	VF90278	1	CIRCUIT BREAKER KIT	
F2	VF90278	1	CIRCUIT BREAKER KIT	
M1	VF90299	1	BRUSH MOTOR AS430-AS510 EU VERSION	
M2	VF90293	1	Motor	
SW1	VV60153	1	Schalter RL2 P	
SW2	VF90252	1	SWITCH	
SW3	VV60153	1	Schalter RL2 P	
SW4	VV60153	1	Schalter RL2 P	
HM B	VF90287	1	HOUR METER	

Part Notes:

[1] - TSB-FC-2019-032 Modified PCBA

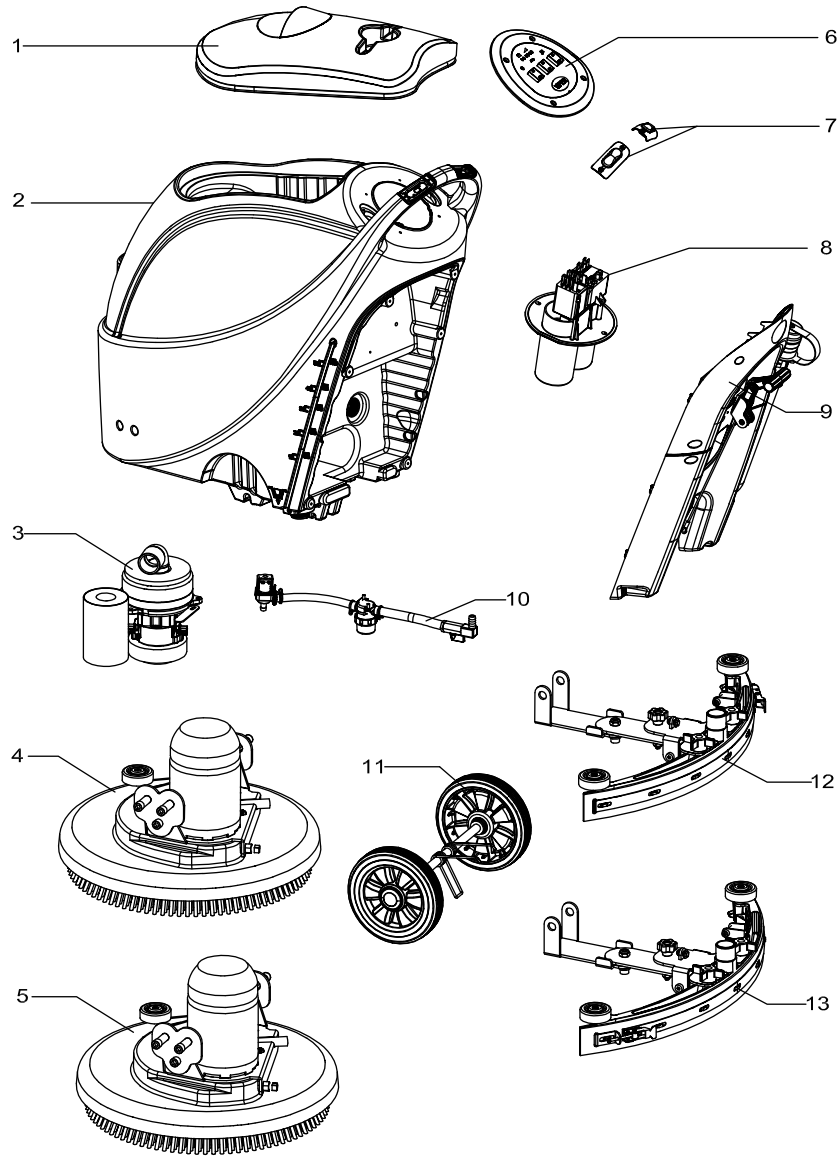

Pos.	Artikel-Nr.	Menge	Variante	Notes
1		1	COVER TANK ASSEMBLY	[1]
2		1	TANK ASSEMBLY	[1]
3		1	SUCTION PUMP SYSTEM	[1]
4B		1	20"BRUSH SYSTEM	[2]
5A		1	17"BRUSH SYSTEM	[2]
6		1	SWITCH PANEL ASSEMBLY	[3]
7		1	SAFETY SWITCH ASSEMBLY	
8		1	ELECTRON COMPONENT ASSEMBLY	[3]
9		1	CONTROL PANEL SYSTEM	[3]
10		1	SOLUTION SYSTEM	[4]
11		1	WHEEL ASSEMBY	[4]
12A		1	17"SQUEEGEE SYSTEM	[5]
13B		1	20"SQUEEGEE SYSTEM	[5]
	VF90069	1	CARTON FOR WOLF1 SERIES	

Part Notes:

- [1] - See CABLE VERSION - TANK SYSTEM
- [2] - See CABLE VERSION - BRUSH SYSTEM
- [3] - See CABLE VERSION - CONTROL SYSTEM AND ELECTRICAL SYSTEM
- [4] - See CABLE VERSION - WHEELS AND SOLUTION SYSTEM
- [5] - See BATTERY AND CABLE VERSION - SQUEEGEE SYSTEM

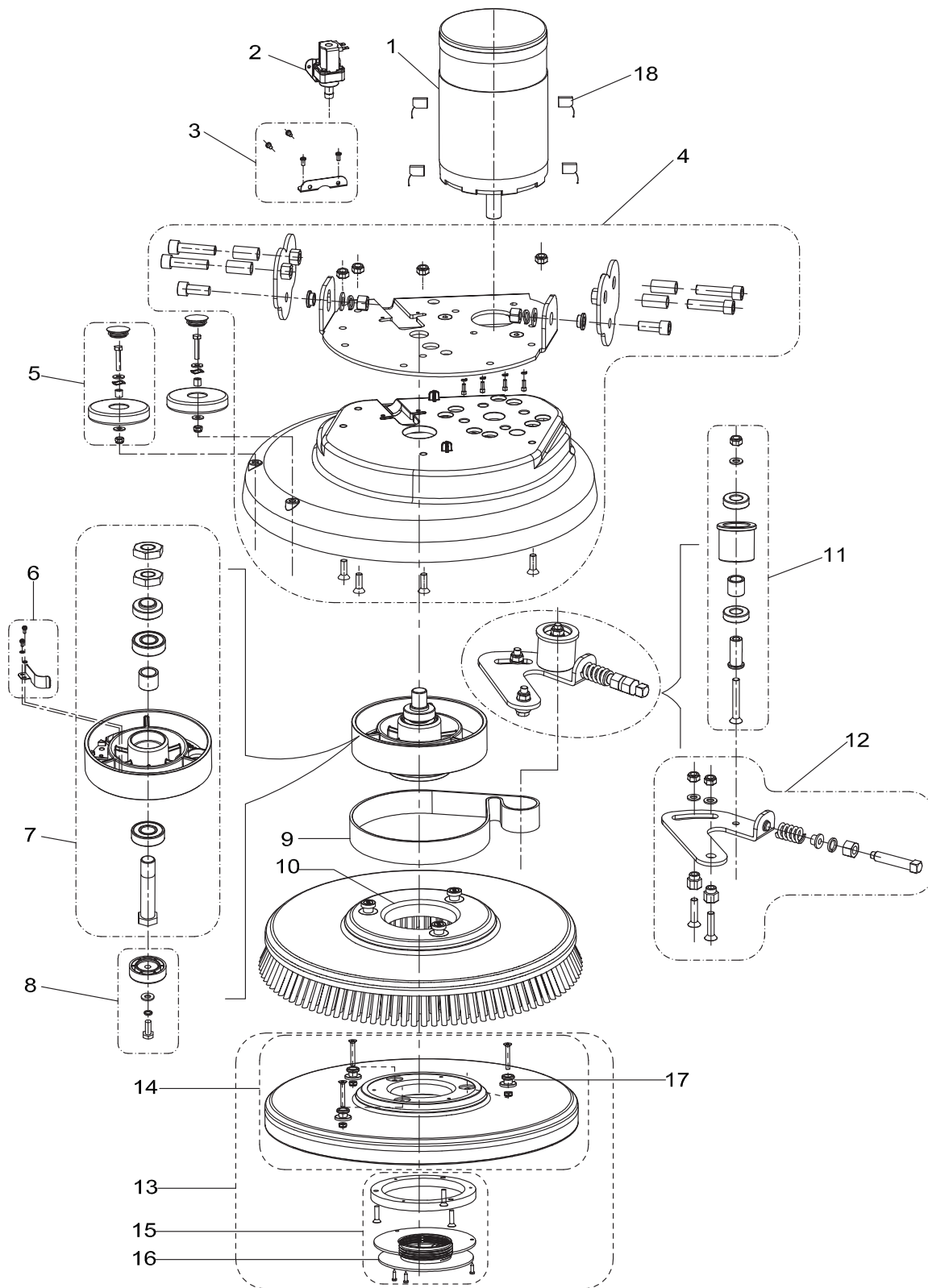

Pos.	Artikel-Nr.	Menge	Variante	Notes
1	VF90299	1	BRUSH MOTOR AS430-AS510 EU VERSION	[1]
1	VF90299	1	BRUSH MOTOR AS430-AS510 EU VERSION	[2]
2	VF90282	1	Magnetventil für AS430/510B+C	
3	VF90447	1	SOLENOID VALVE BRACKET KIT	
4A	VF90448	1	17INCH BRUSH SUPPORT KIT	[3]
4B	VF90449	1	20INCH BRUSH SUPPORT KIT	[4]
5	VS10133	1	BUMPER ROLLER KIT	
6	VF90450	1	BRUSH SPRING CLIP KIT	
7	VF90444	1	DRIVEN PULLEY KIT	
8	VF90451	1	VIBRATION GASKET KIT	
9	VF90408	1	PULLEY BELT	
10A	VF90411	1	17BRUSH	[5]
10B	VF90417	1	20BRUSH	[6]
11	VF90445	1	TENSION WHEEL KIT	[7]
12	VF90452	1	ROD TENSION WHEEL KIT	
13A	VF90453	1	17INCH PAD HOLDER	
13B	VF90454	1	20INCH PAD HOLDER	
14A	VF90428	1	Pad Halter 17 Zoll	[5]
14B	VF90416	1	Pad Halter 20 Zoll	[6]
15	VS10131	1	RETAINER PAD KIT	
16	VF99003A	1	Padhalter	
17	VF90469	3	STUD FOR BRUSH AND PAD DRIVER	
18	VF91041	4	CARBON BRUSH	

Part Notes:

- [1] - Before April 2017
TSB 2017-002 AS430B brush motor improvement
- [2] - after April/10/2017
TSB 2017-002 AS430B brush motor improvement
- [3] - A = Only for AS430B
- [4] - B = Only for AS510B
- [5] - A = Only for AS430B
TSB 2017-004 AS430 AS510 AS5160 bouncing and brush hub improvement
- [6] - B = Only for AS510B
TSB 2017-004 AS430 AS510 AS5160 bouncing and brush hub improvement
- [7] - TSB 2016-005 AS430 AS510 Belt tension pulley improvement

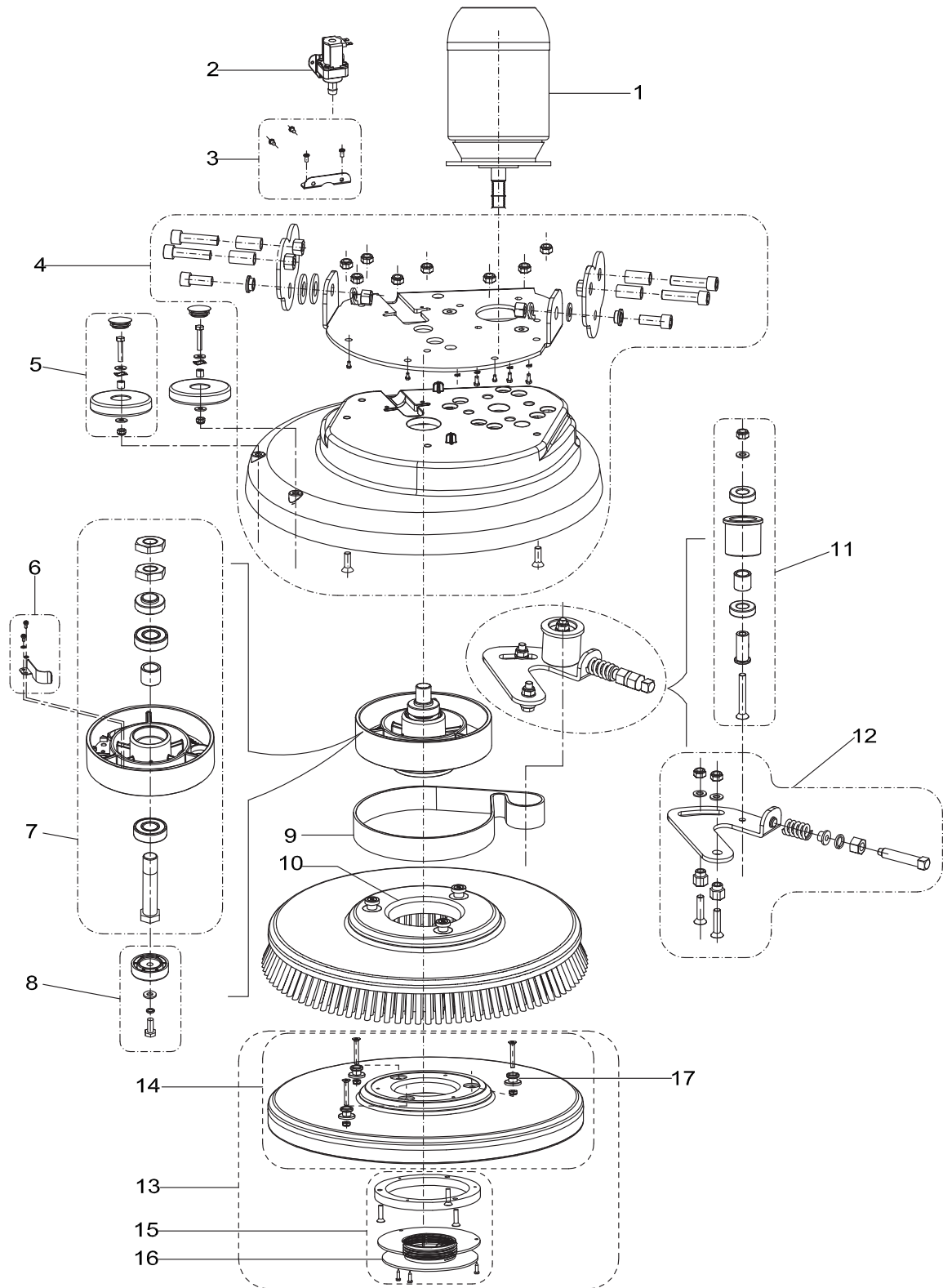

Pos.	Artikel-Nr.	Menge	Variante	Notes
1	VF90728	1	BRUSH MOTOR KIT	
2	VF90283	1	Magnetventilkit	
3	VF90447	1	SOLENOID VALVE BRACKET KIT	
4A	VF90457	1		
4B	VF90458	1		
4A	VF90448	1	17INCH BRUSH SUPPORT KIT	
4B	VF90449	1	20INCH BRUSH SUPPORT KIT	
5	VS10133	1	BUMPER ROLLER KIT	
6	VF90450	1	BRUSH SPRING CLIP KIT	
7	VF90465	1	DRIVEN PULLEY KIT WOLF1 CABLE VERSION	
8	VF90451	1	VIBRATION GASKET KIT	
9	VF90462	1	BELT FOR WOLF1 CABLE VERSION	
10A	VF90411	1	17BRUSH	[1]
10B	VF90417	1	20BRUSH	[1]
11	VF90445	1	TENSION WHEEL KIT	[2]
12	VF90452	1	ROD TENSION WHEEL KIT	
13A	VF90453	1	17INCH PAD HOLDER	[1]
13B	VF90454	1	20INCH PAD HOLDER	[1]
14A	VF90428	1	Pad Halter 17 Zoll	
14B	VF90416	1	Pad Halter 20 Zoll	
15	VS10131	1	RETAINER PAD KIT	
16	VF99003A	1	Padhalter	
17	VF90469	3	STUD FOR BRUSH AND PAD DRIVER	

Part Notes:

- [1] - TSB 2017-004 AS430 AS510 AS5160 bouncing and brush hub improvement
[2] - TSB 2016-005 AS430 AS510 Belt tension pulley improvement

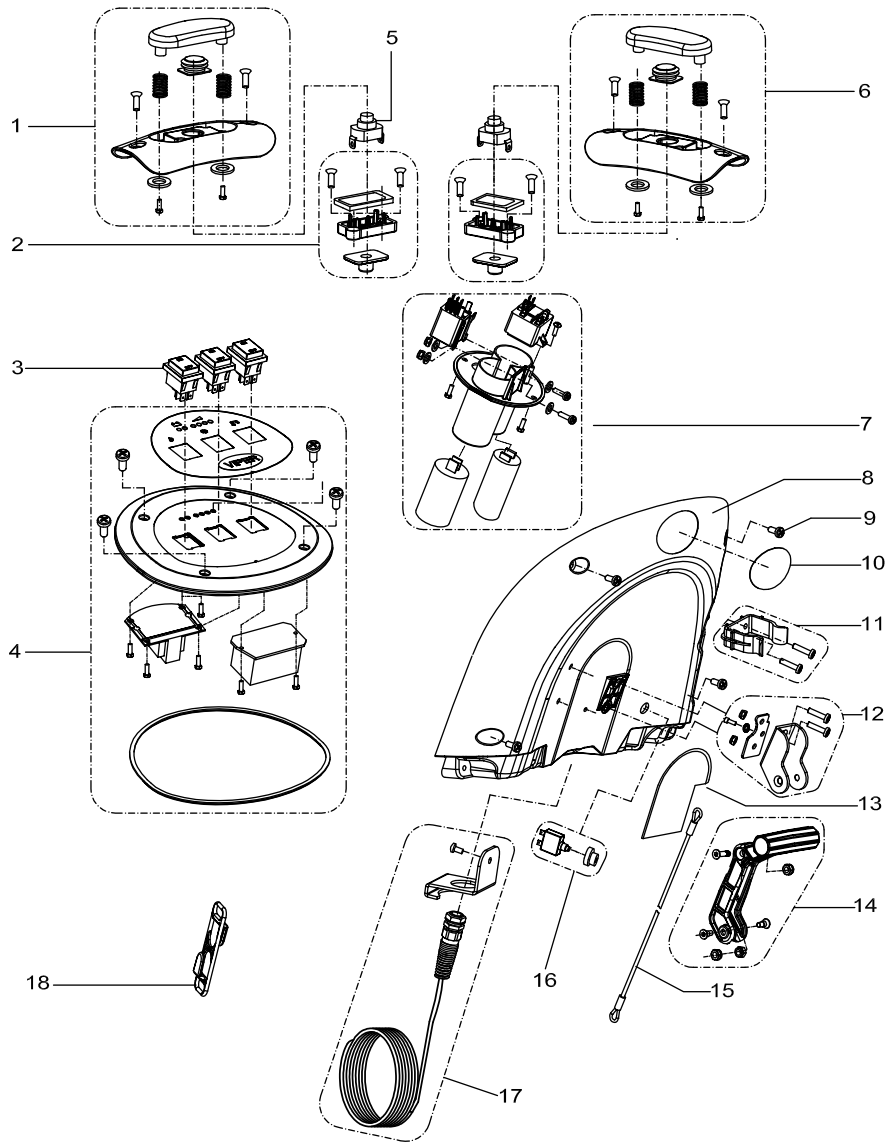

CABLE VERSION - CONTROL SYSTEM AND ELECTRICAL SYSTEM

AS510

2014.06.13

Pos.	Artikel-Nr.	Menge	Variante	Notes
1	VF90266	1	LEFT BUTTON SAFETY SWITCH KIT	
2	VF90268	2	MOUNTING FRAME SWITCH KIT	
3	VV60153	3	Schalter RL2 P	
4	VF90805	1	SWITCH COVER KIT	
5	VF90252	2	SWITCH	
6	VF90267	1	SAFETY SWITCH KNOB LEFT KIT	
7	VF90806	1	ELECTRON COMPONENT	
8	VF90205	1	COVER CONTROL HOUSING	
9	GT13054	4	Flachkopfschraube M5x12	
10A	VF90013-EU	1	SERIAL NUMBER LABEL FOR 17INCH EU	
10A	VF90013-UK	1	SERIAL NUMBER LABEL FOR 17INCH UK	
10B	VF90014-EU	1	SERIAL NUMBER LABEL FOR 20INCH EU	
10B	VF90014-UK	1	SERIAL NUMBER LABEL FOR 20INCH UK	
11	VF90275	1	CLAMP DRAIN HOSE KIT	
12	VF90276	1	HAND BRACKET KIT	
13	VF90010	1	DECAL BACK COVER	
14	VF90277	1	HANDLE LIFT KIT	
15	VF90114	1	CABLE SQUEEGEE LIFT	
16	VF90804	1	CIRCUIT BREAKER KIT	
17	VF90803EU	1	CABLE KIT	
17	VF90803UK	1	CABLE KIT	
18	VF422997	1	HANGING BOARD	

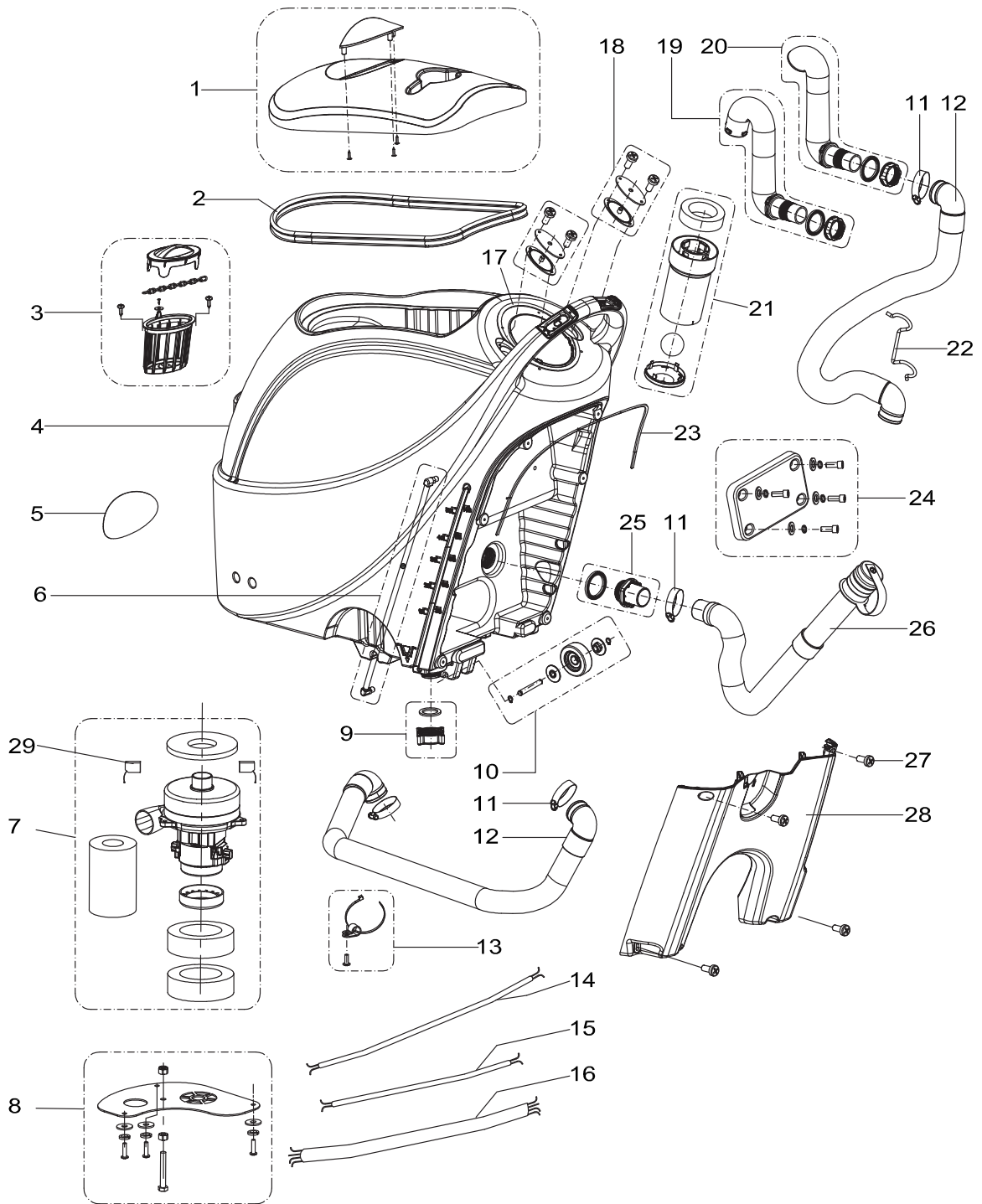

Pos.	Artikel-Nr.	Menge	Variante	Notes
1	VF90535	1	RECOVERY TANK KIT	
2	VF90504	1	Dichtung für Schmutzwassertank	
3	VF90619	1	Tankfilter	
4	VF90519	1	TANK FOR CABLE VERSION	
5	VF90011	1	LOGO LABEL	
6	VF90622	1	WATER LEVEL INDICATION KIT	
7	VF90807	1	Saugmotor Kit	
8	VF90264	1	Motorabdeckung	
9	VF90536	1	ABDECKUNGSSET WASSERABLAUF	
10	VF90312	1	2.5 WHEEL KIT	
11	VA20304	4	CLAMP	
12	VF90508	2	Saugschlauch	
13	VF90537	1	Halterung für Saugschlauch	
13	VF90543	1		
14	VF90720	1	VACUUM MOTOR CONNECTION LINE	
15	VF90730	1	SOLENOID VALVE CONNECTION LINE	
16	VF90721	1	BRUSH MOTOR CONNECTION LINE	
17	VF90231	1	GASKET	
18	VF90265	2	SEAL PLATE KIT	
19	VF90538	1	SUCTION TUBE CONNECTER KIT	
20	VF90539	1	Schmutzwasserschlauch Kit	
21	VF90534	1	FLOAT KIT	
22	VF83150	1	Schlauchhalterung	
23	VF90218	1	CONTROL SEAL GASKET	
24A	VF90801	1	WEIGHT KIT FOR 17INCH	[1]
24B	VF90802	1	WEIGHT KIT FOR 20INCH	[2]
25	VF90446	1	DRAIN HOSE CONNECTER KIT	
26	VF90443	1	Ablassschlauch	
27	GT13054	4	Flachkopfschraube M5x12	
28	VF90206	1	BATTERY COVER	
29	VF90522	1	KOHLEBÜRSTE FÜR VAKUUMMOTOR	

Part Notes:

- [1] - AS430C
 [2] - AS510C

Pos.	Artikel-Nr.	Menge	Variante	Notes
1	VF90504	1	Dichtung für Schmutzwassertank	
2	VF90619	1	Tankfilter	
3	VF90293	1	Motor	
4	VF90536	1	ABDECKUNGSSET WASSERABLAUF	
5	VF90312	1	2.5 WHEEL KIT	
6	VF90508	2	Saugschlauch	
7	VF90534	1	FLOAT KIT	
8	VF90443	1	Ablassschlauch	
9	VF90254	1	WIRE HARNESS MOTOR	
10	VF90247	1	POWER CABLE	
11	VV60153	3	Schalter RL2 P	
12	VF90271-EU	1	CHARGER KIT EU VERSION	
12	VF90271-UK	1	CHARGER KIT UK VERSION	
13	VF90272	1	17 CONTROL PANEL BOARD KIT	
14	VF90252	1	SWITCH	
15	VF90290	1	LED BOARD CONNENTER CABLE KIT	
16	VF90808	2	CIRCUIT BREAKER KIT FOR VACUUM MOTOR	
17	VF90278	1	CIRCUIT BREAKER KIT	
18	VF90114	1	CABLE SQUEEGEE LIFT	
19	VF90281	1	MAIN CABLE KIT	
20	VF90289	1	FUSE KIT	
21	VF90305	2	8 WHEEL	
22	VF90282	1	Magnetventil für AS430/510B+C	
23	VF90621	1	FILTER KIT	
24	VF90624	1	Kugelventilkit	
25	VF90299	1	BRUSH MOTOR AS430-AS510 EU VERSION	
26	VS10133	1	BUMPER ROLLER KIT	
27	VF90450	1	BRUSH SPRING CLIP KIT	
28	VF90444	1	DRIVEN PULLEY KIT	
29	VF90408	1	PULLEY BELT	
30A	VF90411	1	17BRUSH	[1]
30B	VF90417	1	20BRUSH	[2]
31	VF90141	1	Justierknopf	
32	VF81210	2	Flügelmutter	
33	VF90137	2	ROLLER KIT BUMPER	
34	VF90136	2	SQUEEGEE ROLL WHEEL KIT	
35A	VF90103	1	17 BLADE FRONT	[1]
35A	VF90146	1	Sauglippen	[1]
35B	VF90119	1	20 BLADE FRONT	[2]
35B	VF90148	1	Sauglippen	[2]

Part Notes:

- [1] - AS430
 [2] - AS510

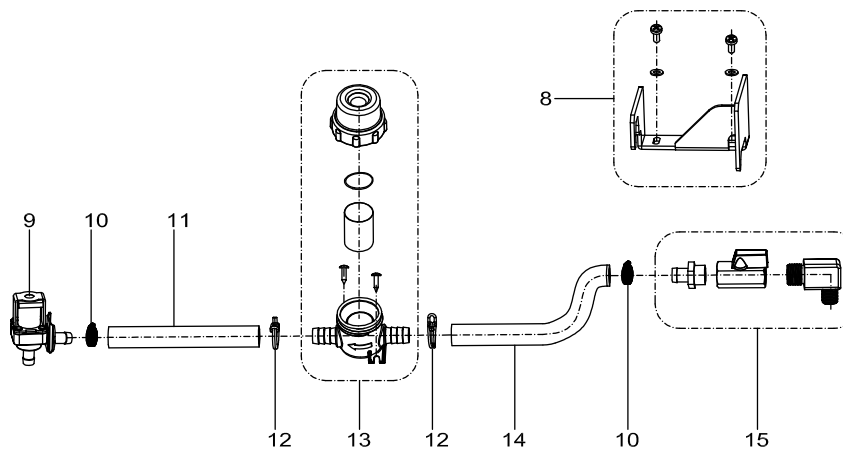
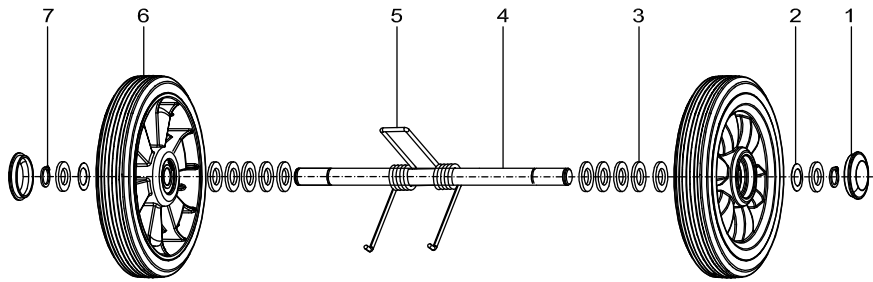

Pos.	Artikel-Nr.	Menge	Variante	Notes
1	VF89203	2	HUB CAP	
2	VF14563	2	WAVE WASHER	
3	VF14554	12	WASHER	
4	VF90304	1	WHEEL SHAFT	
5	VF82172	1	LOCK SPRING	
6	VF90305	2	8 WHEEL	
7	VF14552	2	RING D 17	
8	VF90623	1	SOLENOID VALVE BRACKET KIT	
9	VF90283	1	Magnetventilkit	[1]
10	VV10114	2	Klammer	
11	VF90440	1	TUBING 260MM	
12	VF82148	2	Klammer 16 mm	
13	VF90621	1	FILTER KIT	
14	VF90441	1	TUBING 160MM	
15	VF90624	1	Kugelventilkit	

Part Notes:

[1] - Cable version

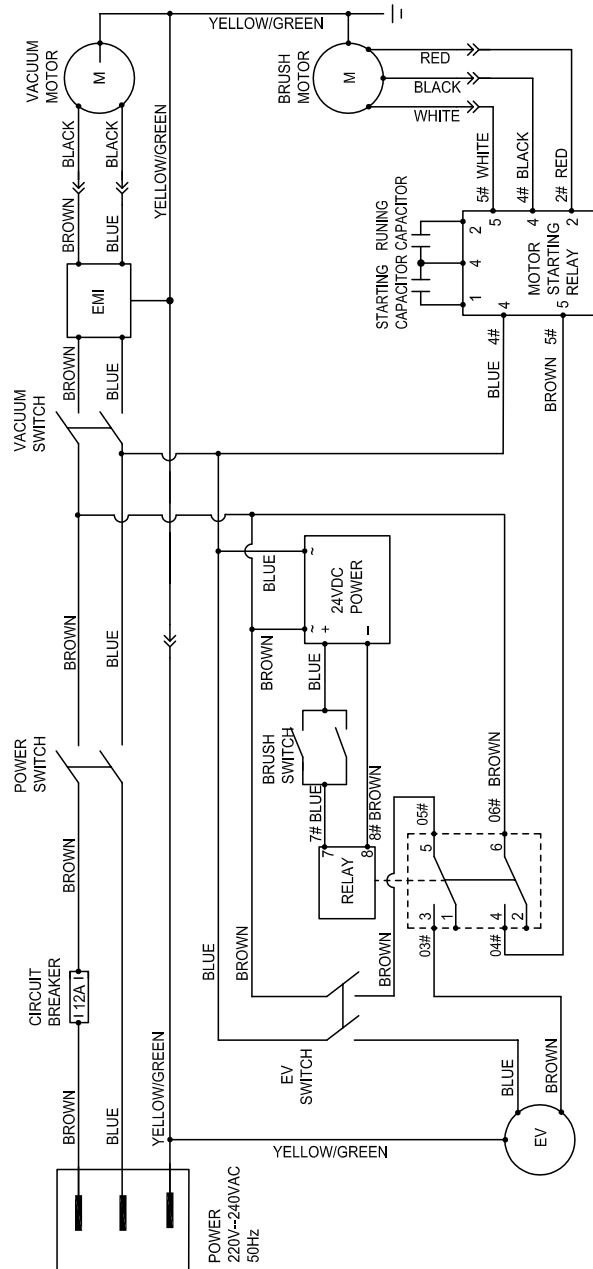

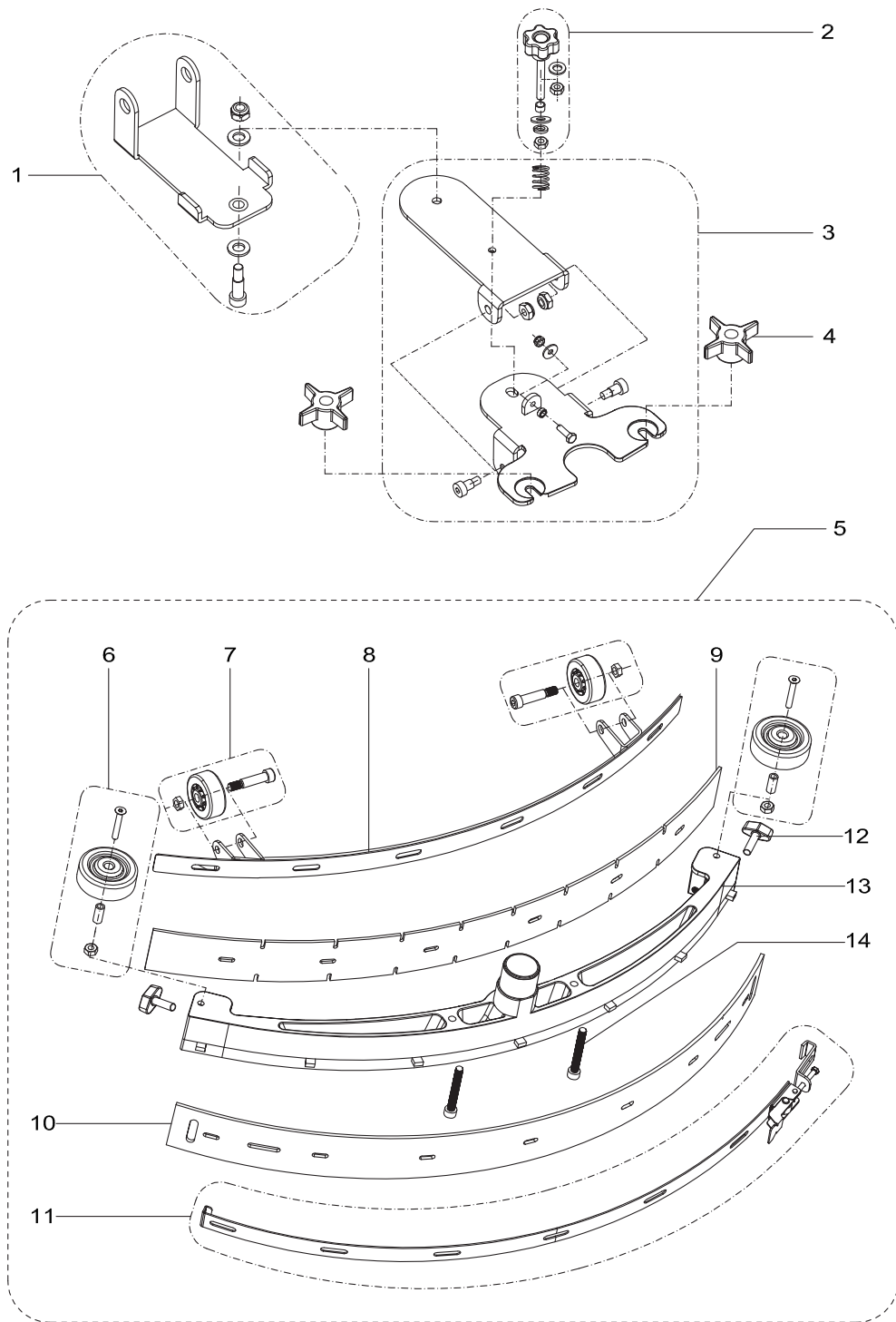

Pos.	Artikel-Nr.	Menge	Variante	Notes
1	VF90140	1	FRONT-SQUEEGEE-SUPPORT KIT	
2	VF90141	1	Justierknopf	
3	VF90142	1	BACK-SQUEEGEE-SUPPORT KIT	
4	VF81210	2	Flügelmutter	
5A	VF90134	1	17 SQUEEGEE KIT	[1]
5B	VF90135	1	20 SQUEEGEE KIT	[2]
6	VF90137	2	ROLLER KIT BUMPER	
7	VF90136	2	SQUEEGEE ROLL WHEEL KIT	
8A	VF90102	1	17INCH STRAP SQUEEGEE FRONT	[1]
8B	VF90118	1	20INCH STRAP SQUEEGEE FRONT	[2]
9A	VF90103	1	17 BLADE FRONT	[1]
9A	VF90146	1	Sauglippen	[1]
9B	VF90119	1	20 BLADE FRONT	[2]
9B	VF90148	1	Sauglippen	[2]
10A	VF90104	1	17 BLADE REAR	[1]
10A	VF90147	1	Sauglippen	[1]
10B	VF90120	1	20 BLADE REAR	[2]
10B	VF90149	1	Sauglippen	[2]
11A	VF90138	1	17INCH STRAP SQUEEGEE BACK KIT	[1]
11B	VF90139	1	20INCH STRAP SQUEEGEE BACK KIT	[2]
12	VF85420	2	KNOB CT 476/30 S-P-M8X30 BP INOX / SS	
13A	VF90101	1	SQUEEGEE 17	[1]
13B	VF90117	1	SQUEEGEE 20	[2]
14	VF90127	2	SQUEEGEE SCREW	

Part Notes:

- [1] - AS430
 [2] - AS510

