

PARTS LIST



2017.05.30

 **Nilfisk**[®]

 07351-5758060

kontakt@nilfisk-alto-shop.com



 **Heine**
Vertriebs-GmbH

Preisabfrage bzw. Bestellungen der Artikel im Shop unter

www.nilfisk-alto-shop.com

einfach die Artikelnummer in die Suchmaske eingeben

(Bitte die Artikelnummer ohne Leerzeichen eingeben)

TABLE OF CONTENTS

General view	1
Chassis system	3
Side broom assembly	5
Hopper system	7
Transmission	9
Right and left hatch assemblies	11
Belt tensioner assemblies	13
Dust control system	15
Vacuum system and filter assembly	17
Control panel system	19
Wiring diagram	21
Recommended spare parts and accessories	23

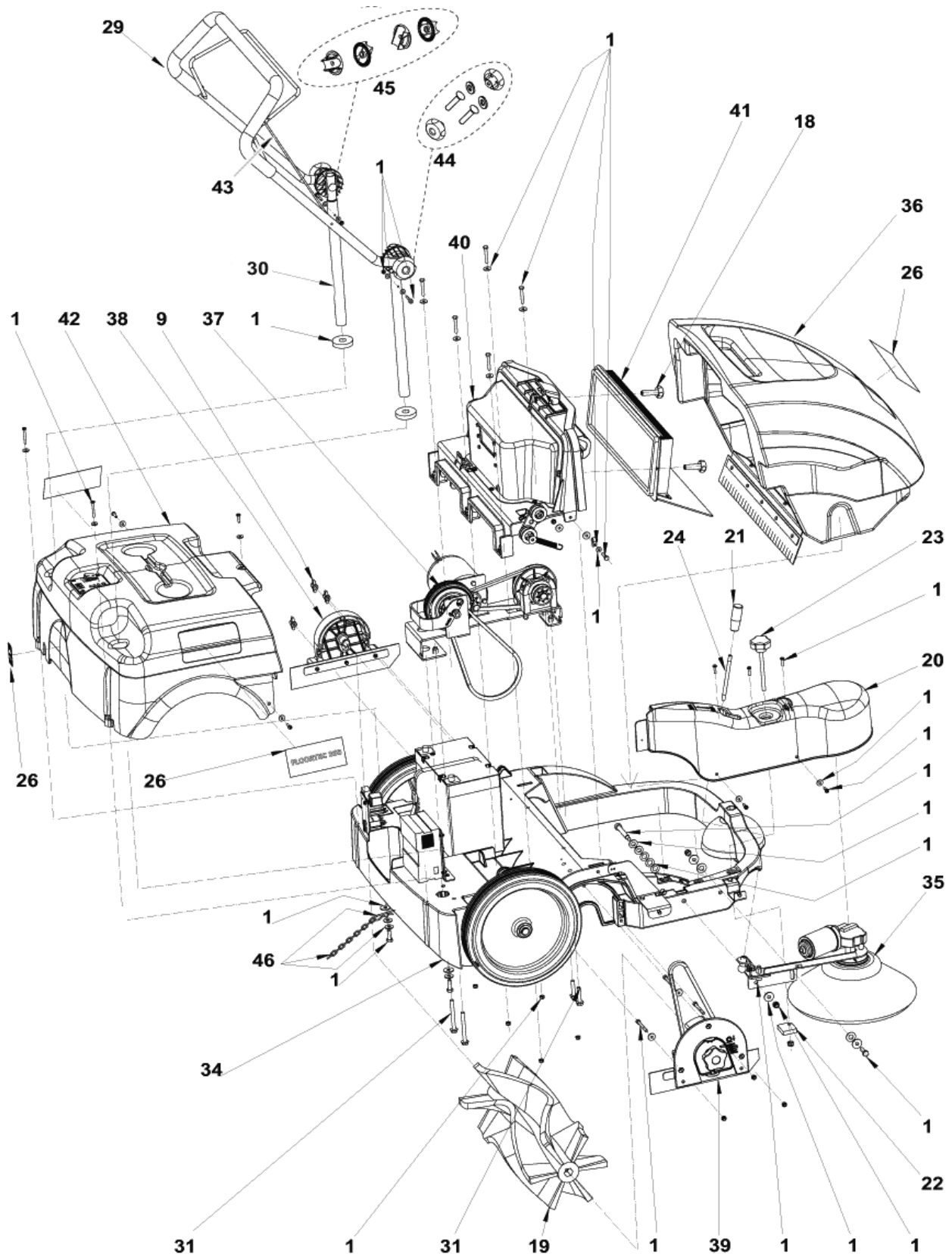

Pos.	Artikel-Nr.	Menge	Variante	Notes
1	1463858000	1	Befestigungskit	
9	909 6356 000	1	Flügelmutter Kit	
18	146 2991 000	2	Handbedienungsrad D.30 M6	
19	1463174000	1	Kehrwalze PP 0,7 200x500 mm	
19	146 3015 000	1	Kehrwalze 200x500 mm, PP 0,3	[1]
19	146 3016 000	1	Kehrwalze 180x500 mm, Naturborsten	[2]
20	1466782000	1	CRANKCASE SIDE BROOM BLACK SIP	
21	146 3037 000	1	Hebel	
22	146 3038 000	1	Justierer	
23	146 3039 000	1	Knauf	
24	146 3040 000	1	Hebel f. Seitenbesen	
26	1466746000	1	DECALS FLOORTEC 350 KIT	[3]
26	1463935000	1	DECALS FLOORTEC 350 ALTO KIT	[4]
29	146 3067 000	1	HANDLE BAR WITH LEVER	
30	1466965000	1	BAR F HANDLE 2 PCS SET	
31	1463868000	1	HARDWARE TRANSMISSION SYST KIT	
34		1	Chassis system	[5]
35		1	Side broom ass.	[6]
36		1	Hopper system	[7]
37		1	Transmission system	[8]
38		1	Left hatch ass.	[9]
39		1	Right hatch ass.	[9]
40		1	Dust control system	[10]
41		1	Filter ass.	[11]
42		1	Control panel ass.	[12]
43	146 3119 000	1	Kabel	
44	1463859000	1	HANDLE FIXING KIT	
45	909 5099 000	1	Stossbügelverstellungzu BA 650/S	
46	1463260000	1	CHAIN GROUND KIT	[2]
47	1463171000	1	Teppichkehrset	[13]

Part Notes:

- [1] - OPTIONAL
- [2] - ACCESSORY
- [3] - Nilfisk-ALTO Brand
- [4] - ALTO Brand
- [5] - Chassis system
- [6] - Side broom assembly
- [7] - Hopper system
- [8] - Transmission
- [9] - Right and left hatch assemblies
- [10] - Dust control system
- [11] - Vacuum system and filter assembly
- [12] - Control panel system
- [13] - NOT SHOWN - OPTIONAL

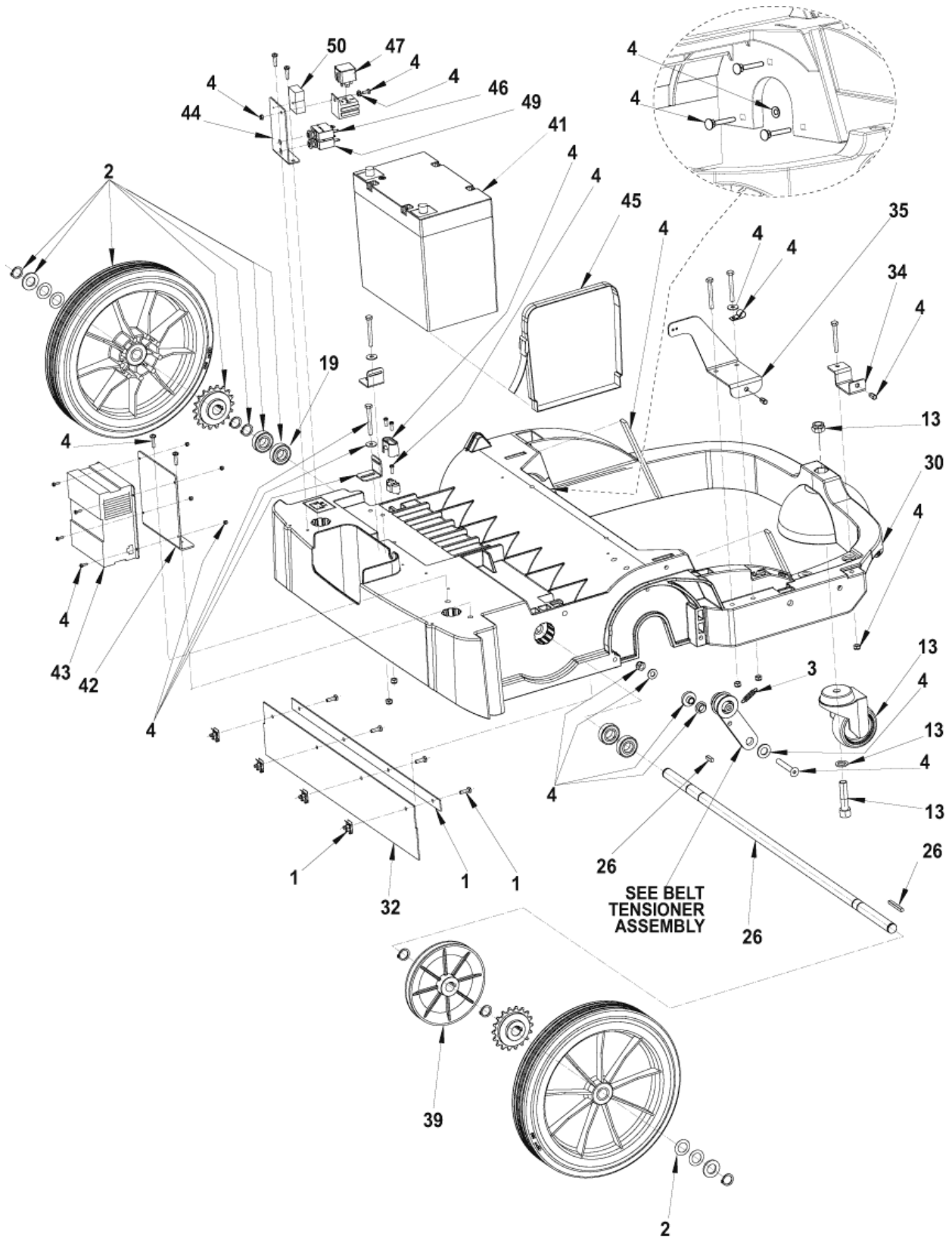

Pos.	Artikel-Nr.	Menge	Variante	Notes
1	146 3124 000	1	Schürze m. Halterkit	
2	1463860000	2	Radkit schwarz	
3	145 8925 000	1	Zugfeder	
4	1463861000	1	BefestigungsKit	
13	1463862000	1	Laufrollenkit	
19	1467030000	4	BEARING BALL 6003 2RS PKD	
26	1463863000	1	SHAFT WHEELS KIT	
30	1466783000	1	CHASSIS PKD	
32	1463166000	1	Gummilippensatz SW 750	
34	146 2983 000	1	BRACKET CARTER FIXING	
35	146 2984 000	1	BRACKET CARTER FIXING	
39	146 2998 000	1	PULLEY D.140	
41	1464483000	1	Batterie 12V-49 Ah, AGM Monoblock	[1]
41	1464853000	1	Gelbatterie 12V-84 Ah	[1]
42	146 3050 000	1	BRACKET BAT.CHARGER FIX	
43	146 3051 000	1	Einbauladegerät 12V-6A 100-230V	
44	146 3053 000	1	SUPPORT ELECTRONIC COMP.	
45	146 3054 000	1	BELT BATTERY FIXING	
46	146 3090 000	1	Sicherung 5A	
47	146 3113 000	1	Relais 12V/70Ah	
49	909 5706 000	1	Hauptschalter 30 A	
50	909 6341 000	1	Sicherungshalter	
51	1467596000	1	FUSE BLADE 7.5A SIP	[2]
52	146 3052 000	1	Kabelbaum	[2]
53	9100000790	1	CABLE EXTENSION EU PLUG L.1000 PKD	[2]
54	9096914000	1	Knickschutz	[2]
55	1466318000	1	CABLE EXTENSION UK PLUG L.2000MM SIP	[2]
56	1463201000	1	BATTERY CLAMPS PLUS-MINUS KIT	[2]
57	1463167000	1	Seitenschürzen-Set, n. mark.	[3]

Part Notes:

- [1] - ACCESSORY - TSB IT 2010-058
- [2] - NOT SHOWN
- [3] - NOT SHOWN - OPTIONAL

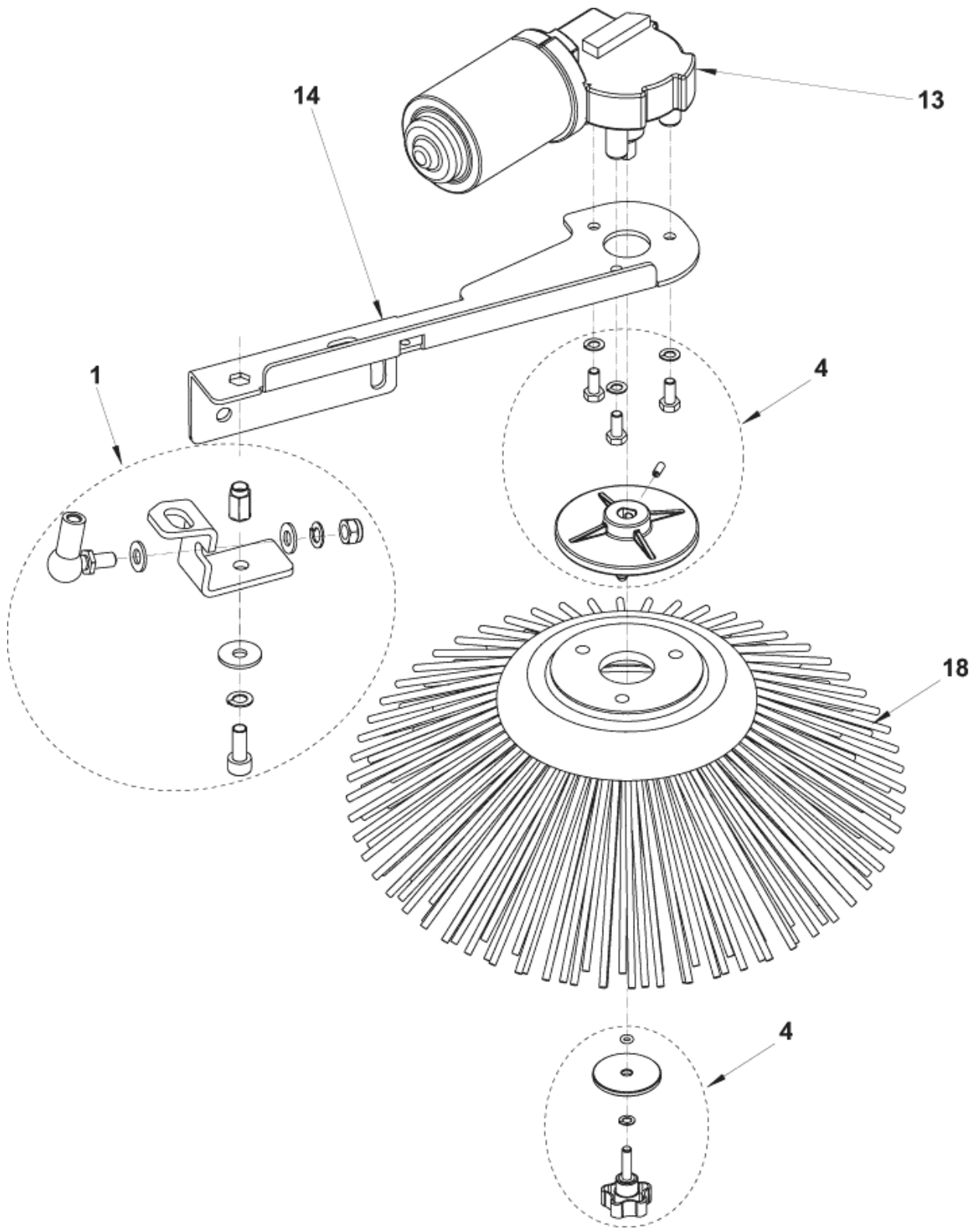

Pos.	Artikel-Nr.	Menge	Variante	Notes
1	1463864000	1	HARDWARE SIDE BROOM KIT	
4	1463865000	1	Schraube SB SW 750	
13	1465999000	1	REDUCTION GEARMOTOR 40W 12V PKD	
14	146 3029 000	1	SUPPORT SIDE BROOM	
18	146 3035 000	1	Seitenbesen 109x315 mm, PP 0,5	
18	146 3036 000	1	Seitenbesen 145x300 mm, Nylon	[1]

Part Notes:

[1] - OPTIONAL

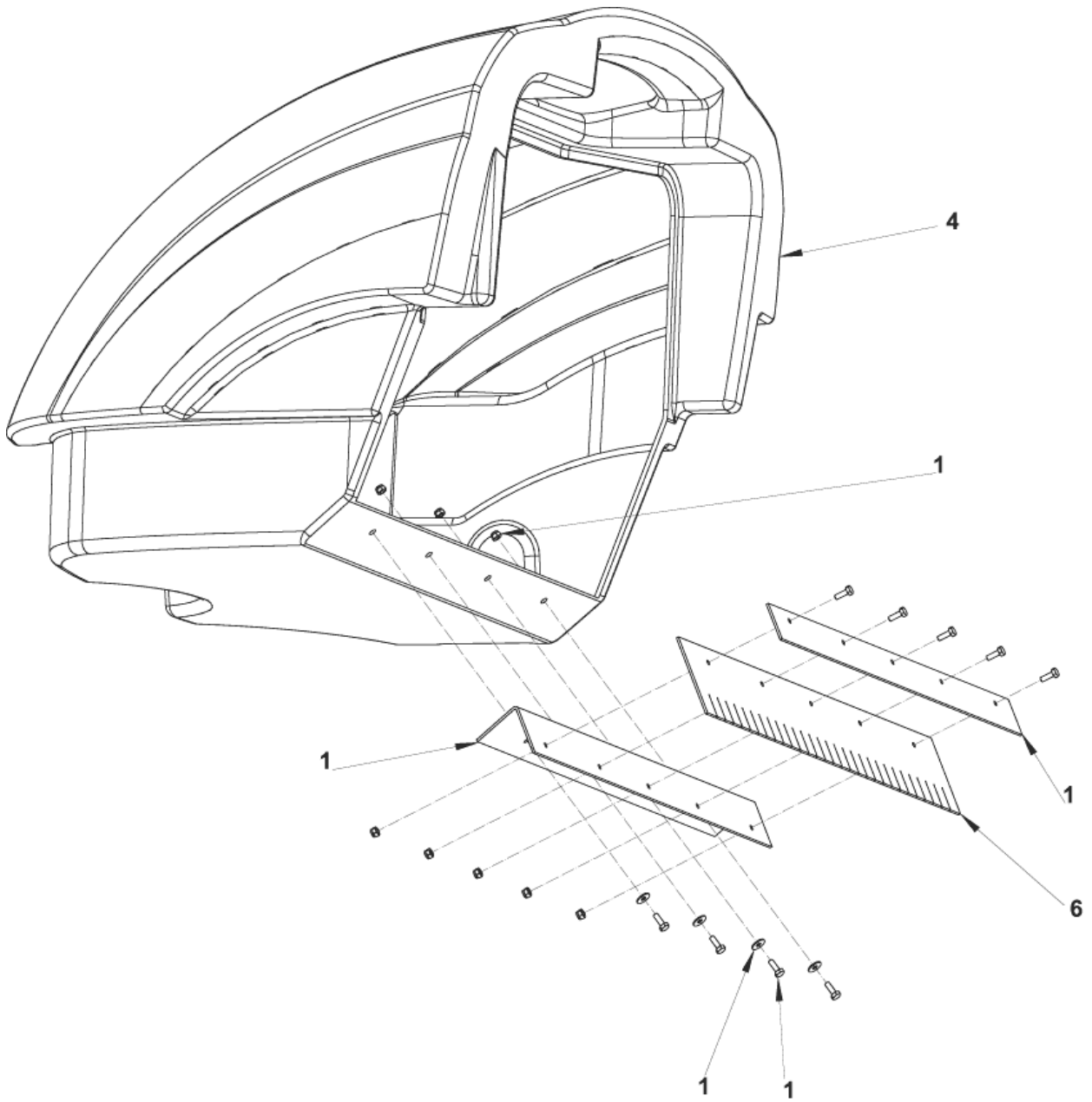

Pos.	Artikel-Nr.	Menge	Variante	Notes
1	146 3124 000	1	Schürze m. Halterkit	
4	146 3043 000	1	Kehrgutbehälter	
6	1463166000	1	Gummilippensatz SW 750	
6	146 3047 000	1	Gummilippe f. Schmutzcon-	

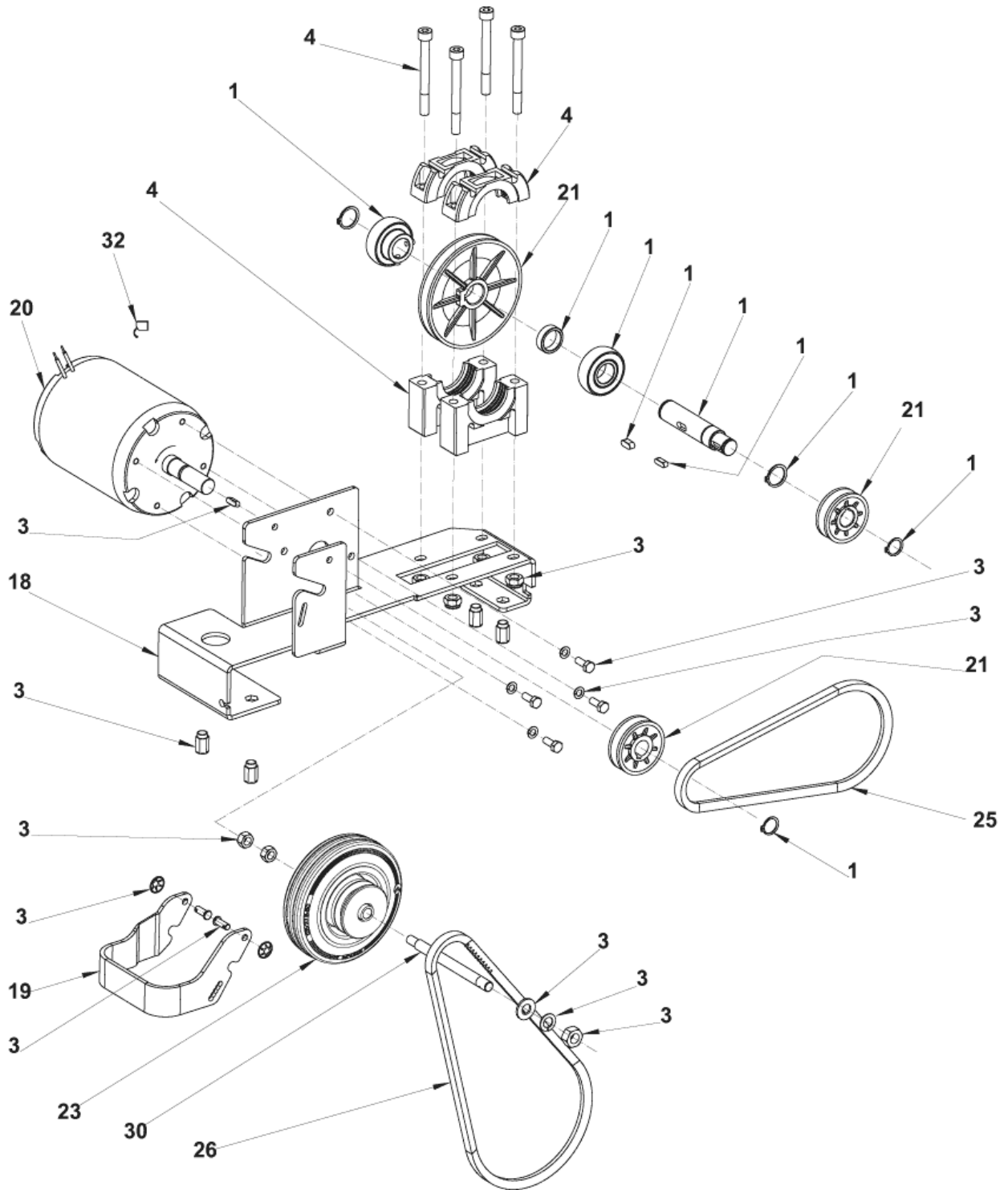

Pos.	Artikel-Nr.	Menge	Variante	Notes
1	1463867000	1	Achsriemenscheibenkit	
3	1463868000	1	HARDWARE TRANSMISSION SYST KIT	
4	1463866000	1	BEARING SUPPORTS KIT	
18	146 3000 000	1	PLATE MOTOR SUPPORT	
19	146 3002 000	1	BRACKET CLUTCH WHEEL	
20	1465998000	1	MOTOR ELECTRIC 200W 12V SIP	
21	1463869000	1	Riemenscheibe	
23	1467647000	1	WHEEL DRIVE CLUTCH KIT	
25	1463305000	1	BELT SPZX 587	
26	1464045000	1	Riemenkit	
30	146 3013 000	1	Achse	
32	909 6893 000	1	Kohlenbürsteset	

ASSIEME PORTELLO SINISTRO - LEFT HATCH ASSEMBLY

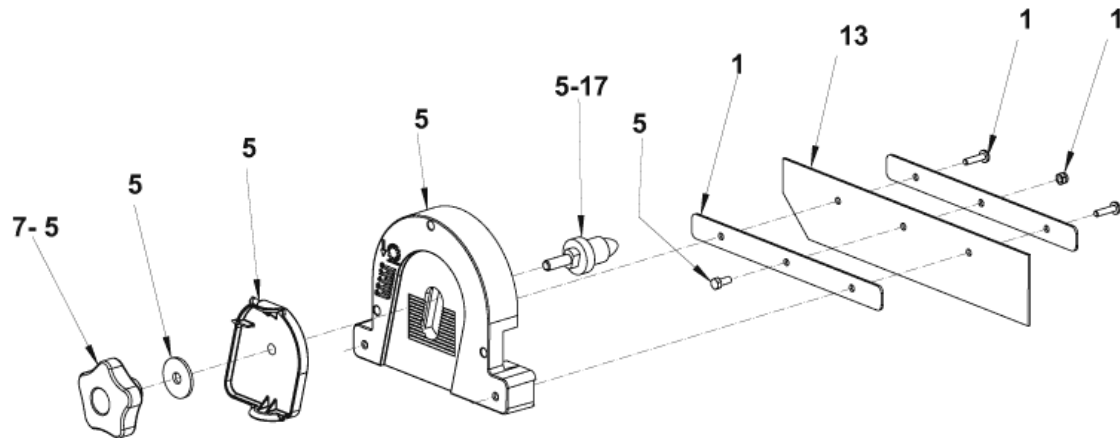

ASSIEME PORTELLO DESTRO - RIGHT HATCH ASSEMBLY

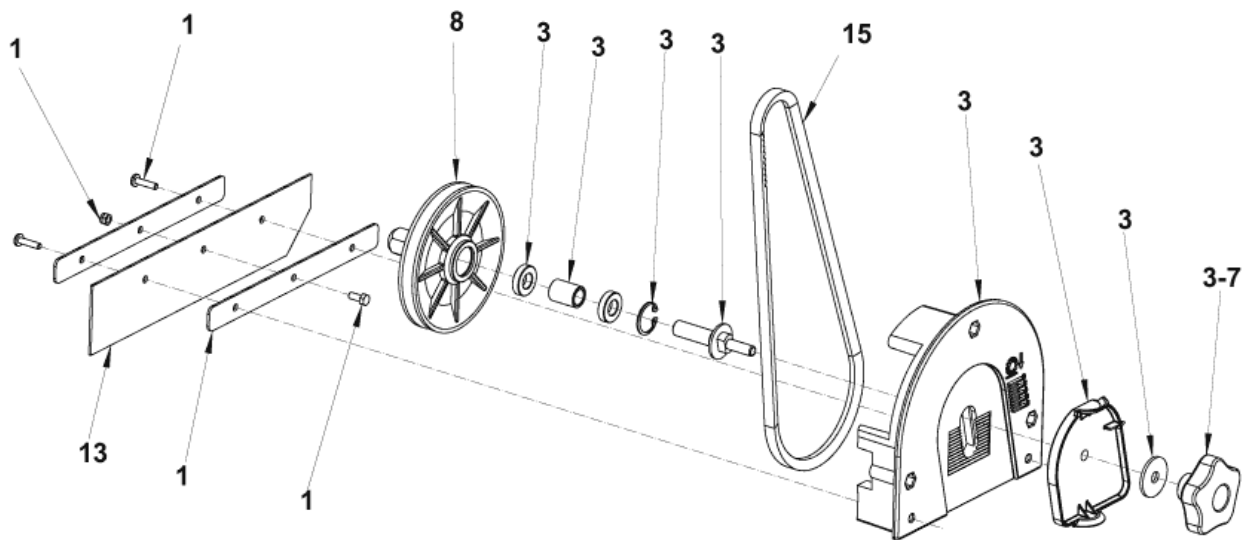

Pos.	Artikel-Nr.	Menge	Variante	Notes
1	146 3124 000	1	Schürze m. Halterkit	
3	1463870000	1	Befestigungskit	
5	1463871000	1	Befestigungskit	
7	146 1852 000	2	Handrad M8 zu BA 650/S	
8	146 3014 000	1	Riemenscheibe 112	
13	1463166000	1	Gummilippensatz SW 750	
15	146 3027 000	1	Keilriemen	
17	146 3020 000	1	Bolzen	

GRUPPO TENDICINGHIA DOPPIO - DOUBLE BELT TENSIONER ASSEMBLY

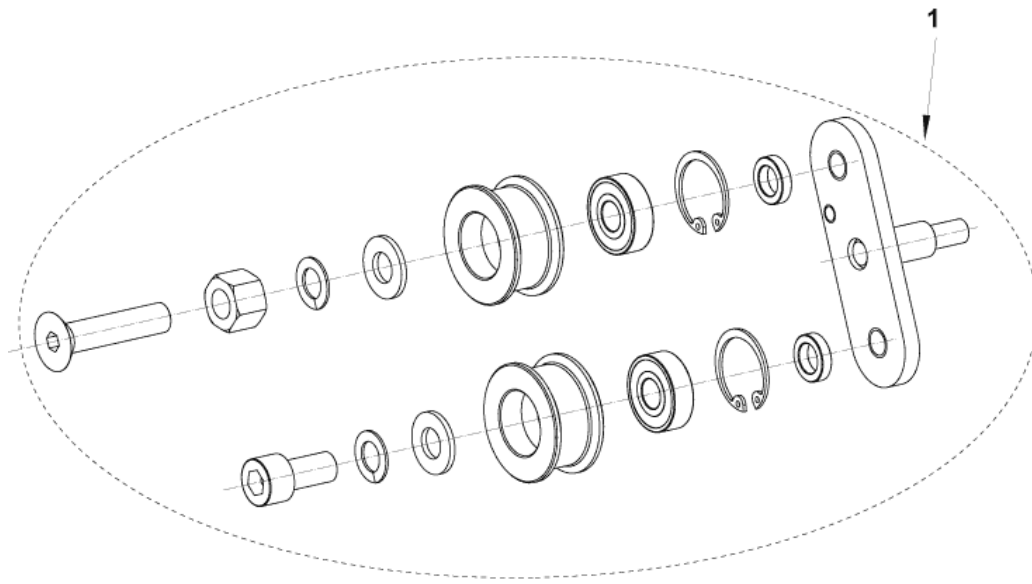

GRUPPO TENDICINGHIA - BELT TENSIONER ASSEMBLY

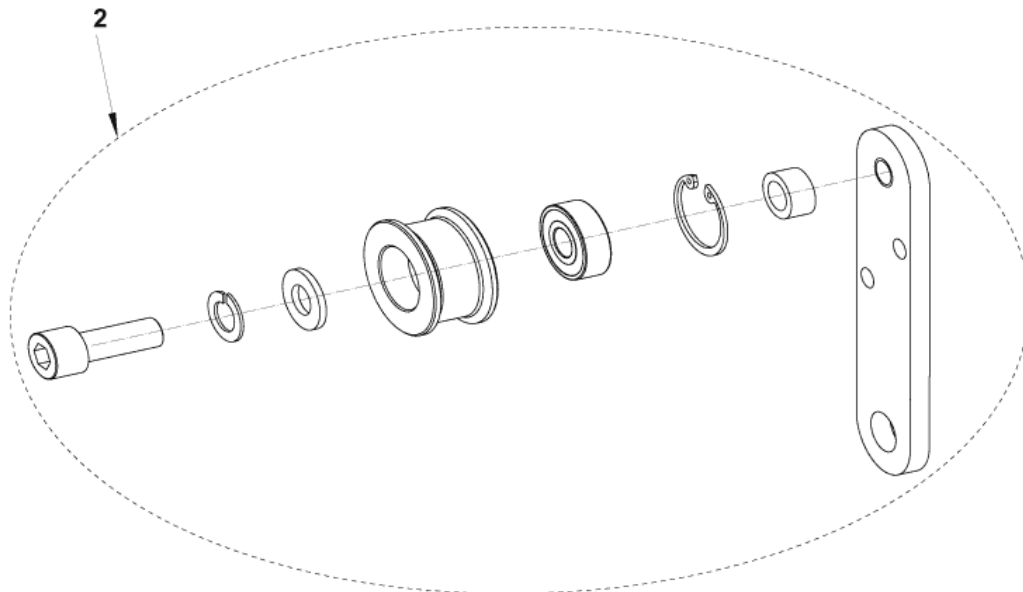

Pos.	Artikel-Nr.	Menge	Variante	Notes
1	1463872000	1	Riemenspanner doppelt KIT	
2	1463873000	1	Riemenspanner Doppelkit	

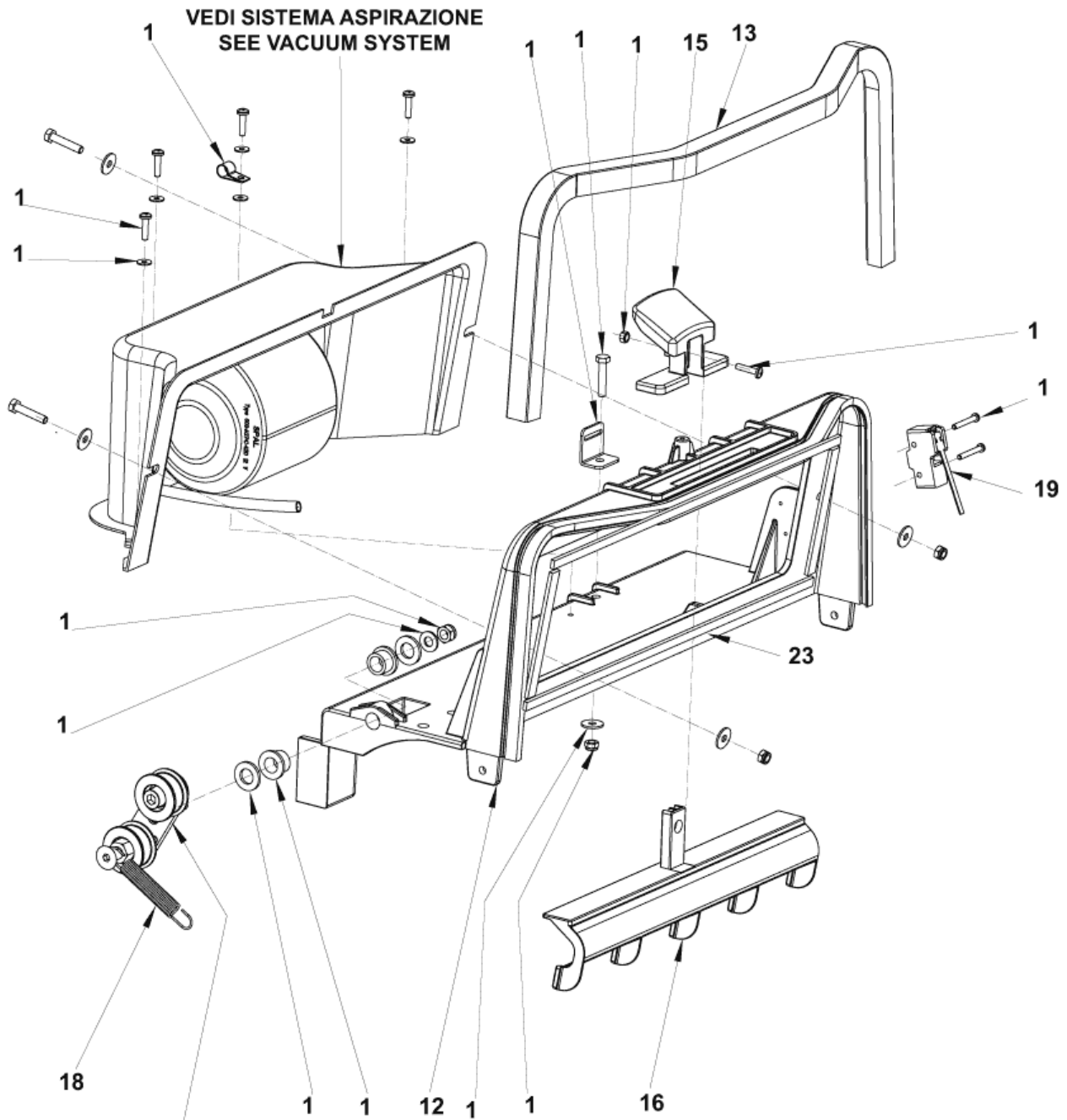

Pos.	Artikel-Nr.	Menge	Variante	Notes
1	1463874000	1	Befestigungskit	
12	146 2988 000	1	Filter f. Floortec 350	
13	1463747000	1	Dichtung L 845mm	
15	146 2992 000	1	HANDLE FILTER SHAKER	
16	146 2993 000	1	FILTER SHAKER	
18	145 0274 000	1	Zugfeder	
19	1466506000	1	MICROSWITCH 10A 250V PKD	
23	1463176000	1	Dichtungs KIT	

ASSIEME ASPIRAZIONE - VACUUM SYSTEM

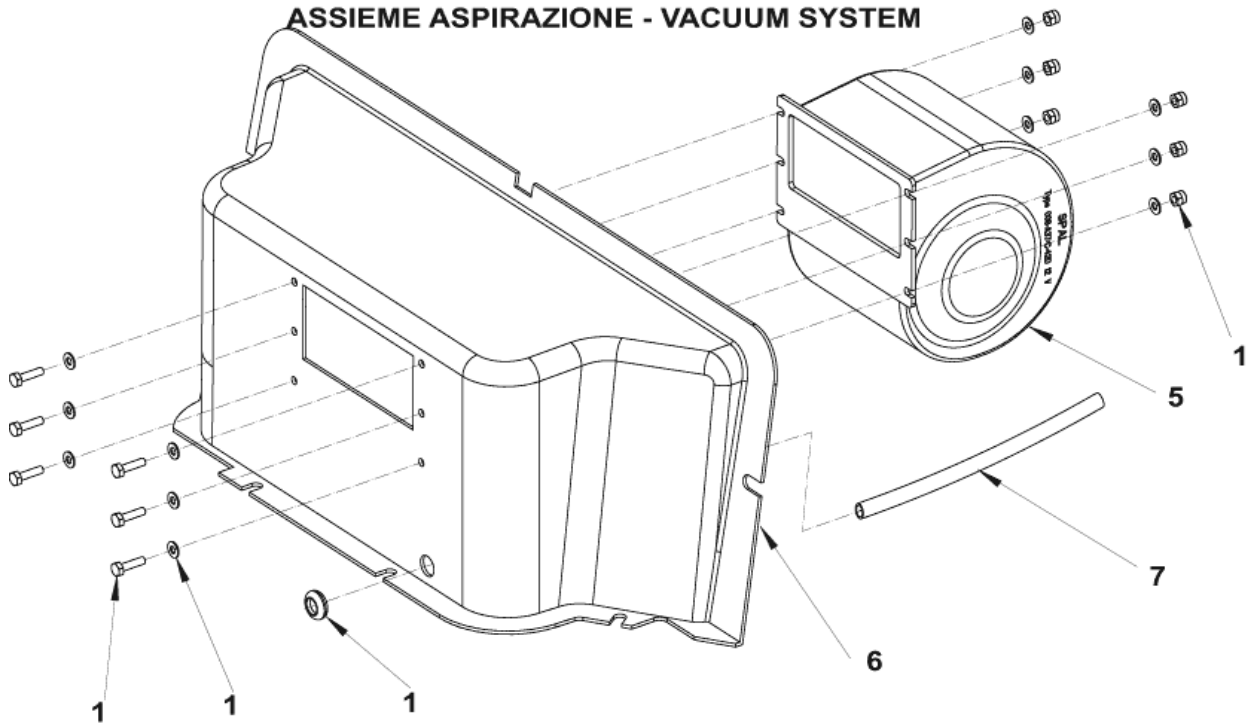

GRUPPO FILTRO - FILTER ASSEMBLY

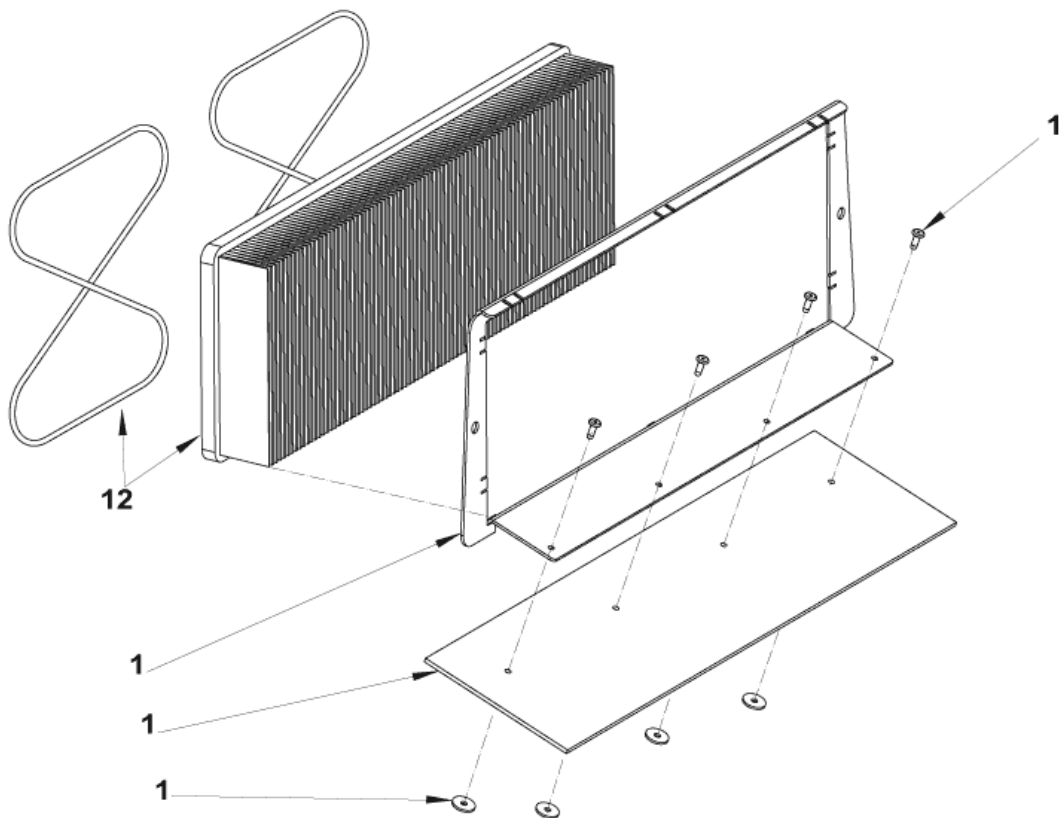

Pos.	Artikel-Nr.	Menge	Variante	Notes
1	1463875000	1	Rahmen	
5	146 1804 000	1	Kühler	
6	146 3055 000	1	CONVEYOR	
7	146 3125 000	1	Hülse	
12	1463161000	1	Filter Polyester	

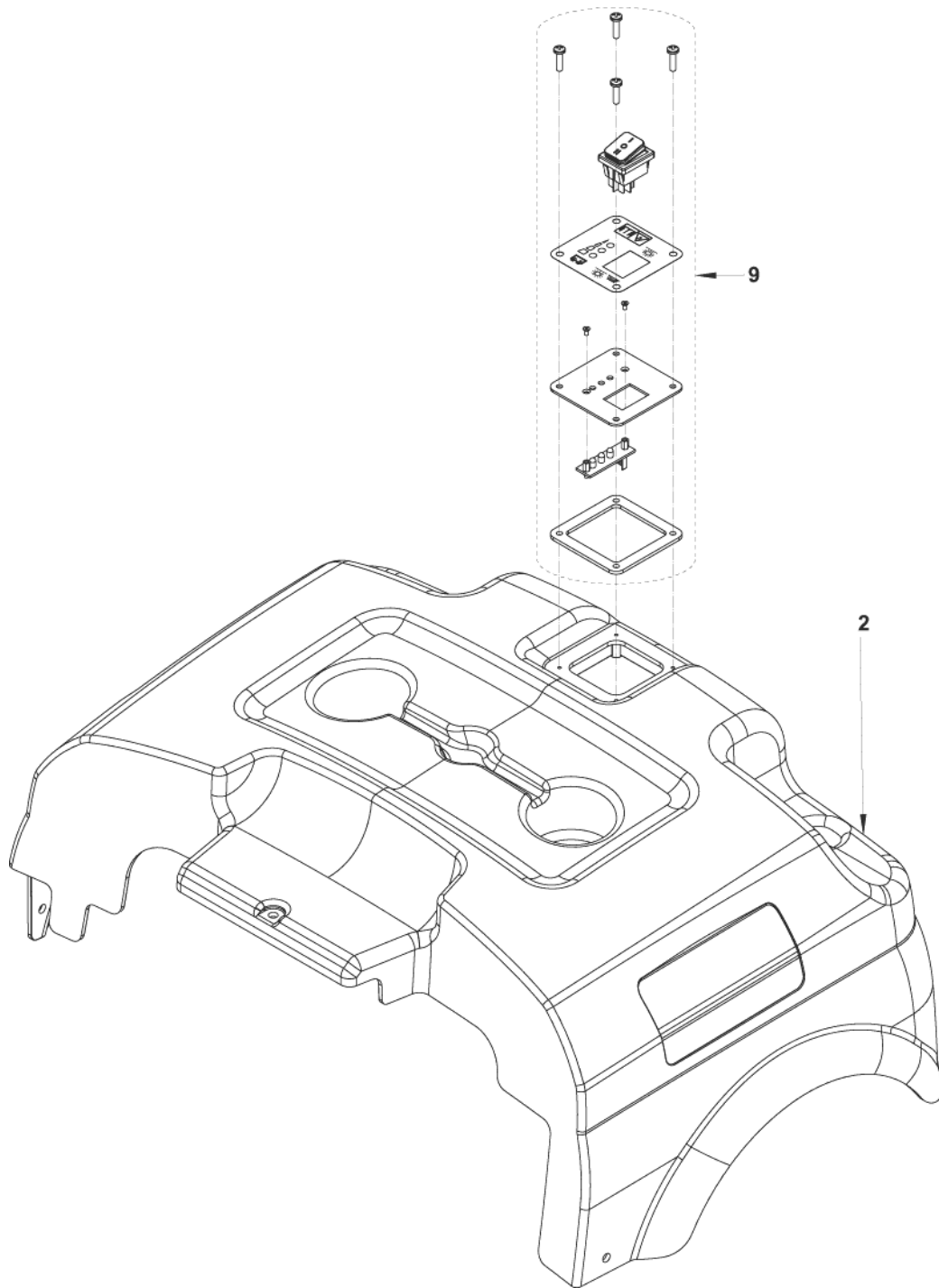

Pos.	Artikel-Nr.	Menge	Variante	Notes
2	1466780000	1	COVER REAR BLACK PKD	
9	1463183000	1	Steuerungspanel W/Decal	

WIRING DIAGRAM

146 3089 000 - Rev.B

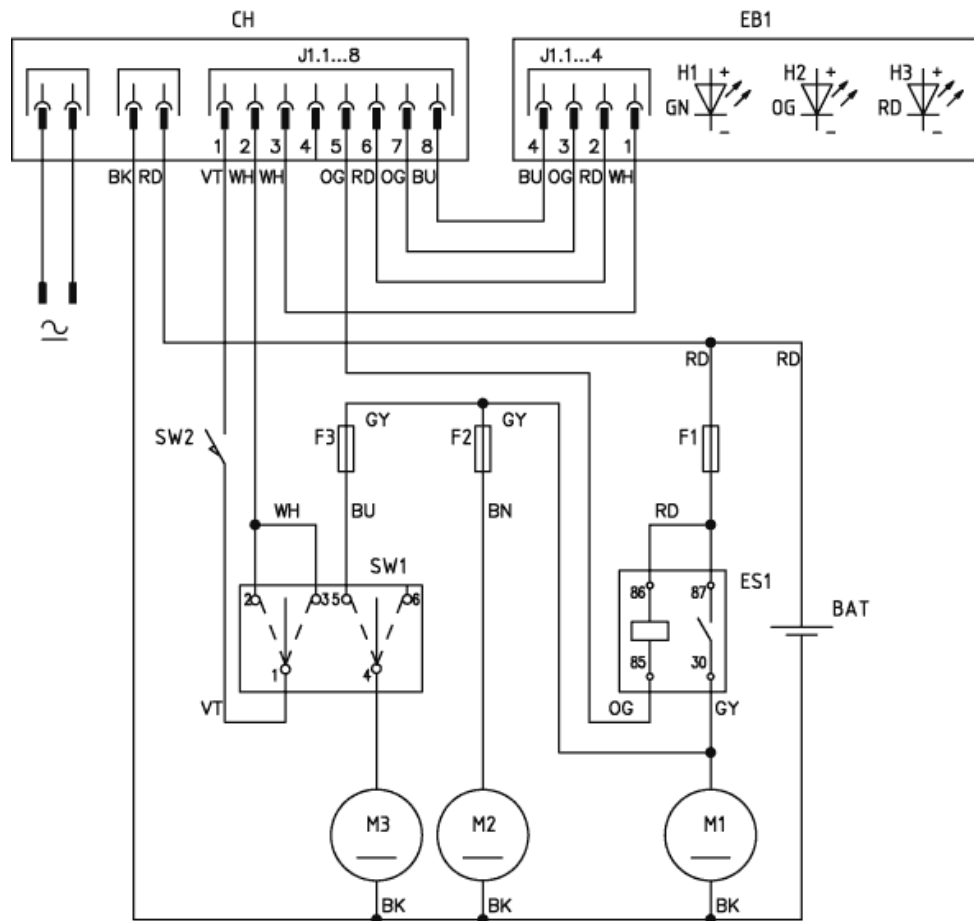

COMPONENTS	
BAT	12V Battery
CH1	Batt. charger / Function controller
EB1	LED board
ES1	Relais
F1	Main circuit breaker
F2	Fan fuse
F3	Side broom circuit breaker
H1	Full charge led
H2	Half charge led
H3	Empty charge led
M1	Main motor
M2	Fan
M3	Side broom motor
SW1	Switch
SW2	Hopper microswitch

Pos.	Artikel-Nr.	Menge	Variante	Notes
------	-------------	-------	----------	-------

Pos.	Artikel-Nr.	Menge	Variante	Notes
01	1463166000	1	Gummilippensatz SW 750	[1]
02	146 3035 000	1	Seitenbesen 109x315 mm, PP 0,5	[1]
03	1463174000	1	Kehrwalze PP 0,7 200x500 mm	[1]
04	146 3027 000	1	Keilriemen	[1]
05	1463161000	1	Filter Polyester	[2]
06	1464045000	1	Riemenkit	[2]
07	1463305000	1	BELT SPZX 587	[2]
08	1463860000	1	Radkit schwarz	[3]
09	146 1804 000	1	Kühler	[3]
10	909 5706 000	1	Hauptschalter 30 A	[3]
11	146 3051 000	1	Einbauladegerät 12V-6A 100-230V	[3]
12	1464483000	1	Batterie 12V-49 Ah, AGM Monoblock	[3]
13	146 3113 000	1	Relais 12V/70Ah	[3]
14	146 3090 000	1	Sicherung 5A	[3]
15	1463183000	1	Steuerungspanel W/Decal	[3]
16	1465998000	1	MOTOR ELECTRIC 200W 12V SIP	[3]
17	1466506000	1	MICROSWITCH 10A 250V PKD	[3]
18	1465999000	1	REDUCTION GEARMOTOR 40W 12V PKD	[3]
19	1464853000	1	Gelbatterie 12V-84 Ah	[4]
20	146 3016 000	1	Kehrwalze 180x500 mm, Naturborsten	[4]
21	146 3015 000	1	Kehrwalze 200x500 mm, PP 0,3	[4]
22	146 3036 000	1	Seitenbesen 145x300 mm, Nylon	[4]
23	1463171000	1	Teppichkehrset	[4]
24	1463167000	1	Seitenschürzen-Set, n. mark.	[4]

Part Notes:

- [1] - WEAR PARTS
- [2] - ORDINARY MAINTENANCE
- [3] - EXTRAORDINARY MAINTENANCE
- [4] - ACCESSORY

